

**EN OWNER'S MANUAL /**

Instructions for Assembly '4 Ft EverMore'

Size 4Ft x 6Ft / 1.1 m x 1.8 m (Approx.)

Ver: 0.0

**FR MANUEL D'INSTRUCTION /**

Instructions pour l'Assemblage '4 Pieds EverMore'

Dimension 4Pieds x 6Pieds / 1.1 Mètre x 1.8 Mètre (Approx.)

Ver: 0.0

**DE Benutzerhandbuch /**

Montageanleitung '4 Ft EverMore'

Größe: 4Ft x 6Ft / 1.1 m x 1.8 m (Ca.)

Ver: 0.0

**ES MANUAL DE USO /**

Instrucciones de montaje '4 Pies EverMore'

Tamaño 4Pies x 6Pies / 1.1 Metros x 1.8 Metros (Aprox.)

Ver: 0.0

**PT MANUAL DO PROPRIETARIO /**

Instruções de montagem '4 pés EverMore'

Tamanho 4pés x 6pés / 1.1 Metro x 1.8 Metro (Aprox.)

Ver: 0.0

**NL Gebruiksaanwijzing voor eigenaar /**

Instructies voor bouw '4 Voet EverMore'

Maat 4voet x 6voet / 1. Meter x 1.8 Meter (Ongeveer)

Versie: 0.0

**CS Příručka uživatele /**

Návod k montáži '4 Stopy EverMore'

Velikost 4Stopy x 6Stopy / 1.1 Metr x 1.8 Metr (Přibližně)

Verze : 0.0

**SK NÁVOD PRE UŽÍVATELA /**

Návod na zloženie '4 Stopa EverMore'

Velkost' 4Stopa x 6Stopa / 1.1 m x 1.8 m (približne)

Pozri: 0.0

**SL PRIROČNIK ZA LASTNIKA /**

Navodila za montažo '4 Čevljev EverMore'

Velikost 4Čevljev x 6Čevljev / 1.1 Metrov x 1.8 Metrov (Približno)

Razl: 0.0

**HR Gazdinski Priručnik /**

Instrukcije za skupštine '4 Stopalo EverMore'

Veličina 4Stopalo x 6Stopalo/ 1.1 Metar x 1.8 Metar (Približno)

Ver: 0.0

**HU FELHASZNÁLÓI KÉZIKÖNYV /**

Útmutató az összeszereléshez '4 Láb EverMore'

4Láb x 6Láb / 1.1 Méter x 1.8 Méter (Hozzávetőlegesen)

Verzió: 0.0

**SV ÄGARENS MANUAL /**

Monteringsinstruktioner för '4 Fot EverMore'

Storlek 4fot x 6fot / 1.1 m x 1.8 m (Ungefär)

Version: 0.0

**IT MANUALE DEL PROPRIETARIO /**

Istruzioni per l'assemblaggio '4 Piedi EverMore'

Dimensione 4Piedi x 6Piedi / 1.1Metri x 1.8Metri (Circa)

Versione 0.0

**PL PODRĘCZNIK UŻYTKOWNIKA /**

Instrukcja montażu '4 Stopy EverMore'

Wymiary 4Stopy x 6Stopy / 1.1 Metr x 1.8 Metr (W przybliżeniu)

Wersja: 0.0

**RO MANUAL DE UTILIZARE /**

Instrucțiuni de asamblare '4 Picioare EverMore'

Mărimē 4Picioare x 6Picioare / 1.1 Metri x 1.8 Metri (Aprox.)

Ver: 0.0

**BG РЪКОВОДСТВО ЗА ПРИТЕЖАТЕЛЯ /**

Инструкции за сглобяване '4 Фута EverMore'

Размер 4Фута x 6Фута / 1.1 Метра x 1.8 Метра (приблизително)

Версия: 0.0

**TR KULLANIM KILAVUZU /**

Montaj Talimatları '4 Fit EverMore'

4Fit x 6Fit / 1.1m x 1.8m (Yaklaşık olarak)

Sürüm: 0.0

**Model # 30625**

EN

### Building Dimensions :

Approximate Size	Storage		Exterior Dimension				Interior Dimension		Door Opening		
	Area	Volume	Base Dimension		Roof Edge to Edge		Wall to Wall				
			inch	cm	inch	cm	inch	cm	inch	cm	
4 Ft x 6 Ft	16 7/8 Sq. Ft	94 3/8 Cu.Ft	43 1/4	109.9	40 3/8	102.7	65 1/8	165.5	22 1/2	57.2	
1.1 m x 1.8 m	1.57 Sq.m	2.67 Cu.m	71	180.5	68 7/8	175	3 3/4	95			
			Height			75 1/4	191.3	66 7/8	170	65	165

Snow load tested max. 20lbs / sq.foot (As per IP Standard)  
 "We recommend to clear snow from the Roof top after each Snowfall."  
 A snow depth of more than 10cm can become hazardous!

FR

### Dimensions du bâtiment :

Taille approximative	Stockage		Dimension extérieure				Dimension intérieure		Ouverture de porte		
	Secteur	Volume	Dimension de base		Toit de bord au bord		Mur à mur				
			pouce	cm	pouce	cm	pouce	cm	pouce	cm	
4 Pieds x 6 Pieds	16 7/8 Carré pieds	94 3/8 Pieds cube	Largeur	43 1/4	109.9	40 3/8	102.7	35 1/2	90.3	22 1/2	57.2
1.1 Mètre x 1.8 Mètre	1.57 Mètre carré	2.67 Mètre cube	Profondeur	71	180.5	68 7/8	175	3 3/4	95		
			Hauteur			75 1/4	191.3	66 7/8	170	65	165

Charge de neige testé max. 20lbs / Carré pieds (conformément à la norme IP)  
 "Nous recommandons d'enlever la neige du Toit après chaque Enneigement."  
 Une épaisseur de neige de plus de 10cm peut devenir dangereux!

DE

### Gebäude Abmessung:

Ungefähre Größe	Speicher		Außen Abmessung				Innen Abmessung		Türöffnung		
	Bereich	Volumen	Fundament Abmessung		Dach Kante bis Kante		( von Wand zu Wand )				
			inch	cm	inch	cm	inch	cm	inch	cm	
4 Ft x 6 Ft	16 7/8 Sq. Ft	94 3/8 Cu.Ft	Breite	43 1/4	109.9	40 3/8	102.7	35 1/2	90.3	22 1/2	57.2
1.1 m x 1.8 m	1.57 Sq.m	2.67 Cu.m	Tiefe	71	180.5	68 7/8	175	3 3/4	95		
			Höhe			75 1/4	191.3	66 7/8	170	65	165

Schneelast max. getestet. 20lbs /sq.Foot (gem. Standard IP)  
 "Wir empfehlen, Schnee von der Dachspitze nach jedem Schneefall zu löschen."  
 Eine Schneetiefe von mehr als 10cm kann gefährlich werden!

ES

### Dimensiones del edificio:

El Tamaño a proximado	Área de almacenaje		Dimensión exterior				Dimensión interior		Abertura de la puerta		
	Área	Volumen	Dimensión de la base		Borde de la azotea al borde		pared a pared				
			Pulgada	cm	Pulgada	cm	Pulgada	cm	Pulgada	cm	
4 Pies x 6Pies	16 7/8 Pies cuadrados	94 3/8 Pies Cúbicos	Anchura	43 1/4	109.9	40 3/8	102.7	35 1/2	90.3	22 1/2	57.2
1.1 Metros x 1.8 Metros	1.57 Metros cuadrados	2.67 Metros Cúbicos	Profundidad	71	180.5	68 7/8	175	3 3/4	95		
			Altura			75 1/4	191.3	66 7/8	170	65	165

Carga de nieve probado max. 20lbs / Pies cuadrados (según el estándar de IP)  
 "Se recomienda limpiar la nieve de la azotea después de cada nevada."  
 Una profundidad de nieve de más de 10cm puede llegar a ser peligrosa!

PT

### Área de Construção:

Dimensão aproximada	Área de Arrumação		Dimensão Exterior				Dimensão Interior		Abertura da Porta		
	Área	Volume	Dimensão da base		Amplitude do Telhado		(Parede a Parede)				
			Polegada	centímetro	Polegada	centímetro	Polegada	centímetro	Polegada	centímetro	
4 pés x 6 pés	16 7/8 Pies quadrado	94 3/8 Pies cúbico	Comprimento	43 1/4	109.9	40 3/8	102.7	35 1/2	90.3	22 1/2	57.2
1.1 Metro x 1.8 Metro	1.57 Metro quadrado	2.67 Metro cúbico	Profundidade	71	180.5	68 7/8	175	3 3/4	95		
			Altura			75 1/4	191.3	66 7/8	170	65	165

Carga de neve testado max. 20lbs / Pies quadrado (conforme padrão IP)  
 "Recomendamos limpar a neve do topo do telhado após cada queda de neve."  
 Uma profundidade de neve de mais de 10cm pode tornar-se perigosa!

NL

## Gebouw afmeting:

Benadering Maat	Opslag		Buitenkant afmeting				Binnenkant afmeting		Deur opening		
	Gebied	Volume	Basis afmeting		Dakrand tot rand		Muur tot muur				
			inch	cm	inch	cm	inch	cm			
4 Voet x 6 Voet	16 7/8 Vierkante voet	94 3/8 Kubieke voet	<b>Wijde</b>	43 1/4	109.9	40 3/8	102.7	35 1/2	90.3	22 1/2	57.2
1.1 m x 1.8 m	1.57 Vierkante meter	2.67 Kubieke meter	<b>Diepte</b>	71	180.5	68 7/8	175	3 3/4	95		
			<b>Hoogte</b>			75 1/4	191.3	66 7/8	170	65	165

Sneeuw belasting getest max. 20lbs / Vierkante voet (volgens het standaard IP-)

“We raden aan sneeuw uit het dak te verwijderen na elke sneeuwval.”

Een sneeuwdiepte van meer dan 10 cm kan gevaarlijk worden!

CS

## Budova rozměr

Přibližné rozměry	Skladování		Vnější rozměr				Vnitřní rozměr		Otevírání dveří		
	Plocha	Objem	Základní rozměr		Na okraj střechy edge		Zdi ke zdi				
			inch	cm	inch	cm	inch	cm			
4 Stopy x 6 Stopy	16 7/8 Čtvereční Stopy	94 3/8 Krychlový Stopy	<b>Šířka</b>	43 1/4	109.9	40 3/8	102.7	35 1/2	90.3	22 1/2	57.2
1.1 Metr x 1.8 Metr	1.57 Čtvereční metr	2.67 Krychlový Metr	<b>Hloubka</b>	71	180.5	68 7/8	175	3 3/4	95		
			<b>Výška</b>			75 1/4	191.3	66 7/8	170	65	165

Zkouška zatížení sněhu max. 20lbs / Čtvereční Stopy (podle normy IP)

“Doporučujeme odstranit sníh ze střešního krytu po každém sněžení.”

Možná hloubka sněhu větší než 10 cm může být nebezpečná!

SK

## Stavebné rozmer

Približné veľkosti	Sklad		Vonkajší rozmer				Interiér rozmer		Otvorenie dverí		
	Priestor	Objem	Base rozmer		Strešné okraja k okraju		Zdi k múru				
			inch	cm	inch	cm	inch	cm			
4 Stopa x 6 Stopa	16 7/8 Stopa štvorcový	94 3/8 Stopa kubický	<b>Šírka</b>	43 1/4	109.9	40 3/8	102.7	35 1/2	90.3	22 1/2	57.2
1.1 m x 1.8 m	1.57 Meter štvorcový	2.67 Meter kubický	<b>Hĺbka</b>	71	180.5	68 7/8	175	3 3/4	95		
			<b>Výška</b>			75 1/4	191.3	66 7/8	170	65	165

Testovanie zaťaženia snehu max. 20lbs / Stopa štvorcový (podľa IP štandardu)

“Odporúčame odstrániť sneh zo strechy po každej snehu.”

Z hĺbky snehu väčšej ako 10 cm sa môže stať nebezpečné!

SL

## Zidanje obseg

približno velikost	Skladiščenje		zunanji obseg				notranji obseg		vrata predrtina		
	Območje	Prostornina	osnova obseg		streha rob v rob		obdati obzidati				
			cola	cm	cola	cm	cola	cm			
4 Čevljev x 6 Čevljev	16 7/8 Kvadratnih Čevljev	94 3/8 Kubičnih Čevljev	<b>širina</b>	43 1/4	109.9	40 3/8	102.7	35 1/2	90.3	22 1/2	57.2
1.1 Metrov x 1.8 Metrov	1.57 Kvadratnih Metrov	2.67 Kubičnih Metrov	<b>globina</b>	71	180.5	68 7/8	175	3 3/4	95		
			<b>višina</b>			75 1/4	191.3	66 7/8	170	65	165

Snow obremenitev testiran max. 20lbs / Kvadratnih Čevljev (po standardu IP)

“Priporočamo, da počistite sneg z vrha strehe po vsakem sneženju.”

Z globino snega več kot 10 cm lahko postane nevarno!

HR

## Zgrada dimenzija

Približno određena mjera	Skladištenje		Vanjski dimenzija				Interijer dimenzija		Vrata Open		
	Područje	Svezak	Temeljiti dimenzija		Krov rub to rub		Zidni to zidni				
			inch	cm	inch	cm	inch	cm	inch	cm	
4 Stopalo x 6 Stopalo	16 7/8 Četvornih Stopalo	94 3/8 Kubni Stopalo	širina	43 1/4	109.9	40 3/8	102.7	35 1/2	90.3	22 1/2	57.2
1.1 Metar x 1.8 Metar	1.57 Četvornih Metar	2.67 Kubni Metar	dubina	71	180.5	68 7/8	175	3 3/4	95		
			visina			75 1/4	191.2	66 7/8	170	65	165

Testirano opterećenje max.20lbs / Četvornih Stopalo (prema IP standardu)  
 “Preporučujemo čišćenje snijega s vrha krova nakon svakog snijega.”  
 Nema dubine snijega veće od 10 cm može biti opasna!

HU

## Építési dimenzió

Hozzávetőleges mérete	Tárolás		Külső méret				A belső dimenzió		Ajtónyitás		
	Terület	Mennyiség	Alap dimenzió		Tető élettől él		A fal és a fal				
			Hüvelyk	cm	Hüvelyk	cm	Hüvelyk	cm	Hüvelyk	cm	
4 Láb x 6 Láb	16 7/8 Négyzet Láb	94 3/8 Köb Láb	Szélesség	43 1/4	109.9	40 3/8	102.7	35 1/2	90.3	22 1/2	57.2
1.1 Méter x 1.8 Méter	1.57 Négyzet méter	2.67 Köbméter	Oldalmagasság	71	180.5	68 7/8	175	3 3/4	95		
			Magasság			75 1/4	191.3	66 7/8	170	65	165

A terhelés max. 20lbs / Négyzet Láb (IP-szabvány szerint)  
 “Javasoljuk, hogy minden hóesést követően tisztítsa meg a havat a tetőtől.”  
 A 10 cm-nél hosszabb hóvastagság veszélyessé válhat!

SV

## Byggnadsdimensioner:

Ungefärlig storlek	Lager		Yttre dimensioner				Inre dimensioner		Dörröppning		
	Area	Volym	Basdimensioner		Tak kant till kant		Vägg till vägg				
			Tum	cm	Tum	cm	Tum	cm	Tum	cm	
4 fot x 6 fot	16 7/8 kvadrat fot	94 3/8 kubik fot	Bredd	43 1/4	109.9	40 3/8	102.7	35 1/2	90.3	22 1/2	57.2
1.1 m x 1.8 m	1.57 kvadratmeter	2.67 kubik meter	Djup	71	180.5	68 7/8	175	3 3/4	95		
			Höjd			75 1/4	191.3	66 7/8	170	65	165

Snow last testas max. 20lbs / kvadrat fot (enligt IP-standard)  
 “Vi rekommenderar att klara snö från taket efter varje snöfall.”  
 Ett snödjup på mer än 10 cm kan bli farligt!

IT

## Dimensioni di Costruzione:

Dimensione approssimativa	Deposito		Dimensione Esterna				Dimensioni Interne		Apertura della Porta		
	Area	Volume	Dimensione della Base		Soffitto da Lato a Lato		Da Muro a Muro				
			Inches	Centimetri	Inches	Centimetri	Inches	Centimetri	Inches	Centimetri	
4 Piedi x 6 Piedi	16 7/8 Piedi Quadrati	94 3/8 Piedi Cubici	Ampiezza	43 1/4	109.9	40 3/8	102.7	35 1/2	90.3	22 1/2	57.2
1.1 Metri x 1.8 Metri	1.57 Metri Quadrati	2.67 Metri Cubici	Profondità	71	180.5	68 7/8	175	3 3/4	95		
			Altezza			75 1/4	191.3	66 7/8	170	65	165

Snow carico testato max. 20lbs / Piedi Quadrati (come per IP standard)  
 “We consigliamo di eliminare la neve dalla tetto del tetto dopo ogni nevicata.”  
 Una profondità di neve di oltre 10 cm può diventare pericolosa!

PL

## Wymiary budowlane:

Przybliżone wymiary	Magazynowa		Wymiary zewnętrzne				Wymiary wewnętrzne		Otwieranie drzwi		
	Powierzchnia	Kubatura	Wymiary fundamentów		Dachu od krawędzi do krawędzi		od ściany do ściany				
			Cal	cm	inch	cm	inch	cm	inch	cm	
4 Stopy x 6 Stopy	16 7/8 Stopy kwadratowy	94 3/8 Stopy sześcienny	<b>Szerokość</b>	43 1/4	109.9	40 3/8	102.7	35 1/2	90.3	22 1/2	57.2
1.1 Metr x 1.8 Metr	1.57 Metr kwadratowy	2.67 Metr sześcienny	<b>Głębokość</b>	71	180.5	68 7/8	175	3 3/4	95		
			<b>Wysokość</b>			75 1/4	191.3	66 7/8	170	65	165

Obciążenia śniegiem testowałem max.20lbs / Stopy kwadratowy(jak na IP Standard)  
 “Zalecamy wyczyszczenie śniegu z dachu dachu po każdym śniegu.”  
 Możliwość śniegu powyżej 10 cm może stać się niebezpieczna!

RO

## Cladirea dimensiuni

Dimensiunea aproximativa	Depozitarea		Dimensiunea exterioara				Dimensiunea interne		deschiderea usii		
	Suprafata	Volumul	Baza dimensiuni		Acoperisul marginea la marginea		perete in perete				
			inch	cm	inch	cm	inch	cm	inch	cm	
4 Picioare x 6 Picioare	16 7/8 Picioare pătrați	94 3/8 Picioare cubi	<b>Latimea</b>	43 1/4	109.9	40 3/8	102.7	35 1/2	90.3	22 1/2	57.2
1.1 Metri x 1.8 Metri	1.57 Metri pătrați	2.67 Metri cubi	<b>Adancimea</b>	71	180.5	68 7/8	175	3 3/4	95		
			<b>Inaltimea</b>			75 1/4	191.3	66 7/8	170	65	165

Rezultatea de încărcare maximă testată. 20lbs / Picioare pătrați (conform standardului IP)  
 “Vă recomandăm să eliminați zăpada din partea superioară a acoperișului după fiecare zăpadă.”  
 O adâncime de zăpadă mai mare de 10 cm poate deveni periculoasă!

BG

## Сградата измерение

Ориентировачна размер	Съхранение		Външно измерение				Министърът на вътрешните измерение		Вратата отваряне		
	Площ	Обем	База измерение		Покрив край до край		Стената на стената				
			Инча	Сантиметра	Инча	Сантиметра	Инча	Сантиметра	Инча	Сантиметра	
4 Фута x 6 Фута	16 7/8 Квадратни Фута	94 3/8 Кубични Фута	<b>Ширина</b>	43 1/4	109.9	40 3/8	102.7	35 1/2	90.3	22 1/2	57.2
1.1 Метра x 1.8 Метра	1.57 Квадратни Метра	2.67 Кубични Метра	<b>Дълбочина</b>	71	180.5	68 7/8	175	3 3/4	95		
			<b>Височина</b>			75 1/4	191.3	66 7/8	170	65	165

Тестване на тежестта на снемане макс. 20lbs / Квадратни Фута (според IP Стандарт)  
 “След всеки снеговалеж препоръчваме да изчистите снега от покрива на покрива.”  
 Дълбочина на снега повече от 10 см може да стане опасна!

TR

## İnşaat boyutu

Tahmini büyüklüğü	Depo		Diş boyutlar				İç boyutu		Kapı açılması		
	Alan	Hacim	Temel boyutundaki		sertliği için harekete		Duvardan duvara				
			İnç	Sanitmetre	İnç	Sanitmetre	İnç	Sanitmetre	İnç	Sanitmetre	
4 Fit x 6 Fit	16 7/8 Metre Fit	94 3/8 Kübik Fit	<b>Genişlik</b>	43 1/4	109.9	40 3/8	102.7	35 1/2	90.3	22 1/2	57.2
1.1 m x 1.8 m	1.57 Metrekare	2.67 metre	<b>Derinlik</b>	71	180.5	68 7/8	175	3 3/4	95		
			<b>Yükseklik</b>			75 1/4	191.3	66 7/8	170	65	165

Saat yükü test max. 20lbs / Metre Fit (IP Standardına göre)  
 “Her Kar yağışı sonrasında Çatı üstten kar temizlemenizi öneririz.”  
 Kar derinliği 10 cm'den fazla tehlikeli olabilir!

**EN Tools You Will Need**

- |                                  |                             |
|----------------------------------|-----------------------------|
| 1. Cordless Drill - Philips Head | 6. Tape Measure             |
| 2. Screwdriver - Philips Head    | 7. Hand Gloves              |
| 3. Carpenters Square             | 8. Waterproof Clear Silicon |
| 4. 8' Step Ladder                | 9. Hammer or Rubber mallet  |
| 5. Level - 3ft.                  |                             |

**FR Outils dont vous aurez besoin**

- |                                     |                                  |
|-------------------------------------|----------------------------------|
| 1. Perceuse sans fil – Tête Philips | 6. Ruban à mesurer               |
| 2. Tournevis - Tête Philips         | 7. Gants                         |
| 3. Équerre du Menuisier             | 8. Silicone neutre étanche       |
| 4. Escabeau 8'                      | 9. Marteau ou maillet caoutchouc |
| 5. Niveau - 3ft.                    |                                  |

**DE Benötigte Werkzeuge**

- |   |                                 |
|---|---------------------------------|
| 1. Akku-Bohrschrauber - Kreuzschlitzbit | 6. Maßband                      |
| 2. Kreuzschlitz-Schraubenzieher         | 7. Handschuhe                   |
| 3. Winkelmaß                            | 8. Wasserdichtes klares Silikon |
| 4. 8' Leiter                            | 9. Hammer oder Gummihammer      |
| 5. Wasserwaage – 1 m                    |                                 |

**ES Equipar con herramienta Usted Necesitará**

- |   |  |
|---|--|
| 1. Taladro inalámbrico - cabeza Philips | 6. Cinta métrica                         |
| 2. Destornillador - cabeza Philips      | 7. Guantes de la mano                    |
| 3. Carpinteros Plaza                    | 8. Silicio transparente a prueba de agua |
| 4. Escalera de 8'                       | 9. Martillo o mazo de goma               |
| 5. Nivelan - 3ft.                       |  |

**PT Ferramentas que irá precisar**

- |                                    |                                      |
|------------------------------------|--------------------------------------|
| 1. Cordless Berbequim              | 6. Fita Métrica                      |
| 2. Chave de fenda – cabeça estrela | 7. Luvas                             |
| 3. Esquadro de carpinteiro         | 8. Silicone Transparente Impermeável |
| 4. Escadote 8"                     | 9. martelo ou malho de borracha      |
| 5. 3ft. Nível                      |                                      |

**NL Gereedschappen die u nodig zult hebben**

- |   |                              |
|---|------------------------------|
| 1. Snoerloze boormachine met gekruiste kop      | 6. Meetlint                  |
| 2. Snoerloze schroevendraaier met gekruiste kop | 7. Handschoenen              |
| 3. Winkelhaak                                   | 8. Waterdicht Clear Silicone |
| 4. Ladder met acht treden                       | 9. Hamer of rubberen hamer   |
| 5. Waterpas                                     |                              |

**CS Budete potřebovat toto nářadí**

- |                                 |                            |
|---------------------------------|----------------------------|
| 1. Bezdrátová vrtačka - Philips | 6. Svinovací metr          |
| 2. Vrták - Philips              | 7. Rukavice                |
| 3. Tesařské náměstí             | 8. Vodotěsný čistý silikon |
| 4. 8mí stupňový žebřík          | 9. Kladivo nebo kaučuk     |
| 5. Vodováha - 3ft.              |                            |

**SK Nástroje, ktoré budete potrebovať**

- |                                      |                                 |
|--------------------------------------|---------------------------------|
| 1. Bezdrôtová vrtačka - Philips Head | 6. Meter                        |
| 2. Šraubovák – Philips Head          | 7. Rukavice                     |
| 3. Stolársky meter                   | 8. Vodotesný čistý silikon      |
| 4. 8' Rebrík                         | 9. Kladivo alebo gumená palička |
| 5. Zdvihák – 3 stopy.                |                                 |

**SL Orodje, ki ga boste potrebovali**

- |                                    |                                  |
|------------------------------------|----------------------------------|
| 1. Brezžična vrtalna- glava Philip | 6. Merilni trak                  |
| 2. Vijačnik-glava Philip           | 7. Rokavice                      |
| 3. Mizarski kvadrat                | 8. Vodoodporni Clear Silicone    |
| 4. 2438,4 mm dvokraka lestev       | 9. Kladivo za kladivo ali kavčuk |
| 5. Nivelirka - 0,91 m              |                                  |

**HR Alati, Trebat će Vam**

- |                                      |                                  |
|--------------------------------------|----------------------------------|
| 1. Bežični Svrdlo – Philips Voditelj | 6. Traka Divizor                 |
| 2. Vijak Vozač - Philips Voditelj    | 7. Ručni Rukavice                |
| 3. Drvodjelac Četverokut             | 8. Vodonepropusni bistri silikon |
| 4. 8' Korak Ljestve                  | 9. Čekić ili gumeni čekić        |
| 5. Razina – 3 stoplo.                |                                  |

**HU A szükséges szerszámok**

- |                                       |                             |
|---------------------------------------|-----------------------------|
| 1. Vezeték nélküli fúró – csillagfejű | 6. Mérőszalag               |
| 2. Csavarhúzó – csillagfejű           | 7. Kesztyűk                 |
| 3. Ácsderékszög                       | 8. Vízálló, tiszta szilikon |
| 4. 8-fokú létra                       | 9. Hammer vagy gumi sisak   |
| 5. Vízszintmérő.                      |                             |

**SV Verktyg du kommer att behöva**

- |                                      |                              |
|--------------------------------------|------------------------------|
| 1. Sladdlös bormaskin - Philips borr | 6. Måttband                  |
| 2. Skruvmejsel - krysshuvud          | 7. Verktygshandskar          |
| 3. Vinkelhake                        | 8. Vattentät Klar Silikon    |
| 4. 8-fots stege                      | 9. Hammer eller Gummihammare |
| 5. vattenmätt – 3fot.                |                              |

**IT Gli Attrezzi di cui Avrai Bisogno**

- |  |                                      |
|--|--------------------------------------|
| 1. Trapano senza fili – Punta a stella | 6. Metro a Nastro                    |
| 2. Cacciavite – Punta a stella         | 7. Guanti                            |
| 3. Squadra metallica                   | 8. Silicone trasparente impermeabile |
| 4. Scala ad 8 pioli                    | 9. Martello o martello di gomma      |
| 5. Livello – 3 piedi                   |                                      |

**PL Potrzebne narzędzia**

- |   |                                      |
|---|--------------------------------------|
| 1. Bezprzewodowa wkrętarka – krzyżakowa | 6. Taśma miernicza                   |
| 2. Śrubokręt krzyżakowy                 | 7. Rękawice ochronne                 |
| 3. Kątownik stolarski                   | 8. Wodoodporny przezroczysty silikon |
| 4. 8' Drabina składana                  | 9. Młotek lub młotek gumowy          |
| 5. Poziomica – 91,4 cm                  |                                      |

**RO Instrumentele de care aveți nevoie**

- |                                     |                                    |
|-------------------------------------|------------------------------------|
| 1. Șurubelniță – cap Philips        | 6. Ruletă de măsurat               |
| 2. Mașină de găurit – cap Philips   | 7. Mănuși de protecție             |
| 3. Echer de dulgherie               | 8. Silicon transparent impermeabil |
| 4. Scară cu trepte de 8' (20.32 cm) | 9. Ciocan sau ciocan din cauciuc   |
| 5. Nivel - 3ft.                     |                                    |

**BG Инструменти, които ще ви трябват**

- |   |                              |
|---|------------------------------|
| 1. Безжична бормашина - с глава Philips | 6. Рулетка                   |
| 2. Отвертка – с глава Philips           | 7. Ръкавици                  |
| 3. Прав ъгъл                            | 8. Водоустойчив ясен силикон |
| 4. Стълба – 20 см (8')                  | 9. Чук или гумен чук         |
| 5. Нивелир – 1 м (3ft).                 |                              |

**TR İhtiyaç duyacağınız aletler**

- |                                    |                               |
|------------------------------------|-------------------------------|
| 1. Kablosuz Matkap- Philips Başlık | 6. Mezura                     |
| 2. Tornavida-Philips Başlık        | 7. Eldiven                    |
| 3. Marangoz gönyesi                | 8. Su geçirmez Şeffaf Silikon |
| 4. 8 Basamaklı Merdiven            | 9. Çekiç veya Kauçuk tokmak   |
| 5. Seviye- 91,5 cm.                |                               |

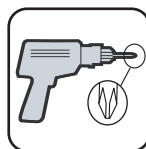

1

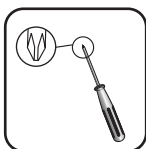

2



3



4

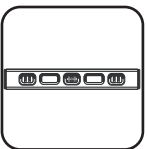

5



6



7

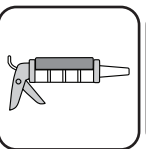

8

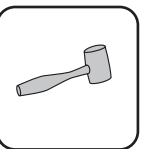

9

**EN** Parts List

**FR** Liste des pièces

**DE** Teileliste

**ES** La Lista de Partes

**PT** Lista de Peças

**NL** Onderdelenlijst

**CS** Seznam součástí

**SK** Zoznam častí

**SL** Seznam delov

**HR** Dijelovi Lists

**HU** Alkatrésztlista

**SV** Komponentlista

**IT** Lista delle varie parti

**PL** Lista części

**RO** Lista elementelor componente

**BG** Списък на частите

**TR** Parça Listesi

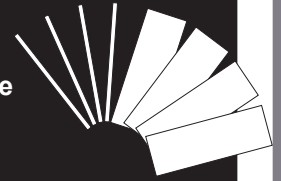

- EN** 1. Check all parts prior to installation.  
2. Before starting installation, please refer to Safety & Precautions.

- FR** 1. Vérifier toutes les pièces avant l'installation.  
2. Avant de commencer l'installation, référez-vous svp à Sécurité et Précautions.

- DE** 1. Prüfen Sie alle Teile vor der Montage.  
2. Lesen Sie vor dem Aufbau die Sicherheitsanweisungen.

- ES** 1. Verifica todo despide antes de instalación.  
2. Antes de comenzar la instalación, consulte Seguridad y Precauciones.

- PT** 1. Confirme todas as peças antes da instalação.  
2. Antes de iniciar a instalação, cheque item "Segurança e Cuidados".

- NL** 1. Controleer vooraf of alle onderdelen aanwezig zijn.  
2. Voordat u begint met installeren, verwijzing naar veiligheid voorschriften.

- CS** 1. Něž začnete s montáží, zkontrolujte všechny součásti.  
2. Před montáží si prosím přečtete Bezpečnost a bezpečnostní opatření.

- SK** 1. Skontrolujte všetky časti pred inštaláciou.  
2. Skôr ako začnete s inštaláciou, prečítajte si Bezpečnosť a bezpečnostné opatrenia.

- SL** 1. Pred montažo preverite vse dele.  
2. Pred začetkom namestitve, glejte VARNOST & VARNOSTNI UKREPI.

- HR** 1. Provjera svih dijelova prije instalacije.  
2. Prije nego Vi počete instalacija, molim vas pogledajte Sigurnost i mjere opreza

- HU** 1. Ellenőrizzen minden alkatrészt az összeszerelés megkezdése előtt.  
2. Az összeszerelés megkezdése előtt kérjük vegye figyelembe a biztonsági utasításokat.

- SV** 1. Kolla alla delar före installationen.  
2. innan man startar installationen ska man läsa igenom säkerhet & försiktighetsåtgärder.

- IT** 1. Controlla tutte le parti prima dell'installazione.  
2. Prima di incominciare con l'installazione, per favore leggi attentamente i punti illustrati nel paragrafo Sicurezza ed Installazione.

- PL** 1. Sprawdź wszystkie części zanim przystąpisz do montażu.  
2. Przed rozpoczęciem instalacji należy przeczytać rozdział Bezpieczeństwo i środki ostrożności.

- RO** 1. Verificați toate părțile componente înainte de instalare.  
2. Înainte de a începe asamblarea, consultați capitolul. Măsuri de siguranță și protecție.

- BG** 1. Проверете всички части преди монтажа.  
2. Преди започване на монтажа, моля разгледайте Безопасност и Защита.

- TR** 1. Kurulumdan önce tüm parçaları kontrol ediniz.  
2. Montaja başlamadan önce lütfen Güvenlik ve Önlemler kısmına bakınız.





	VCH01	1
	VCH02	1
	VRH01	2
	VRH02	1
	VRH03	1
	VRH04	2
	VRH05	2
	VRH06	2
	VRH07	1
	VRH08	1
	VRH09	1
	VRH11	2
	VRH12	2
	VRH10	1
	VDRH	1
	VDLH	1
	VDTH	1
	RPH1	2
	SPH1	2
	SPH2	2
	SPH3	1
	SPH4	1
	SPH5	1
	FPH1	1
	BPH1	1
	RPH2	1
	DH	1
	CCH1	4

	PPG	24
	PIN	24
	TC	4
	BCRR	10
	BFLT	1
	BFRT	1
	BP	6
	FP	4
	F1	4
	S1	55
	S2	4
	S7	37
	SGC1	3
	SAC1	6
	S5	14
	S6	18





- 1 → #10-21
- 2 → #22-35
- 3 → #36-39
- 4 → #40

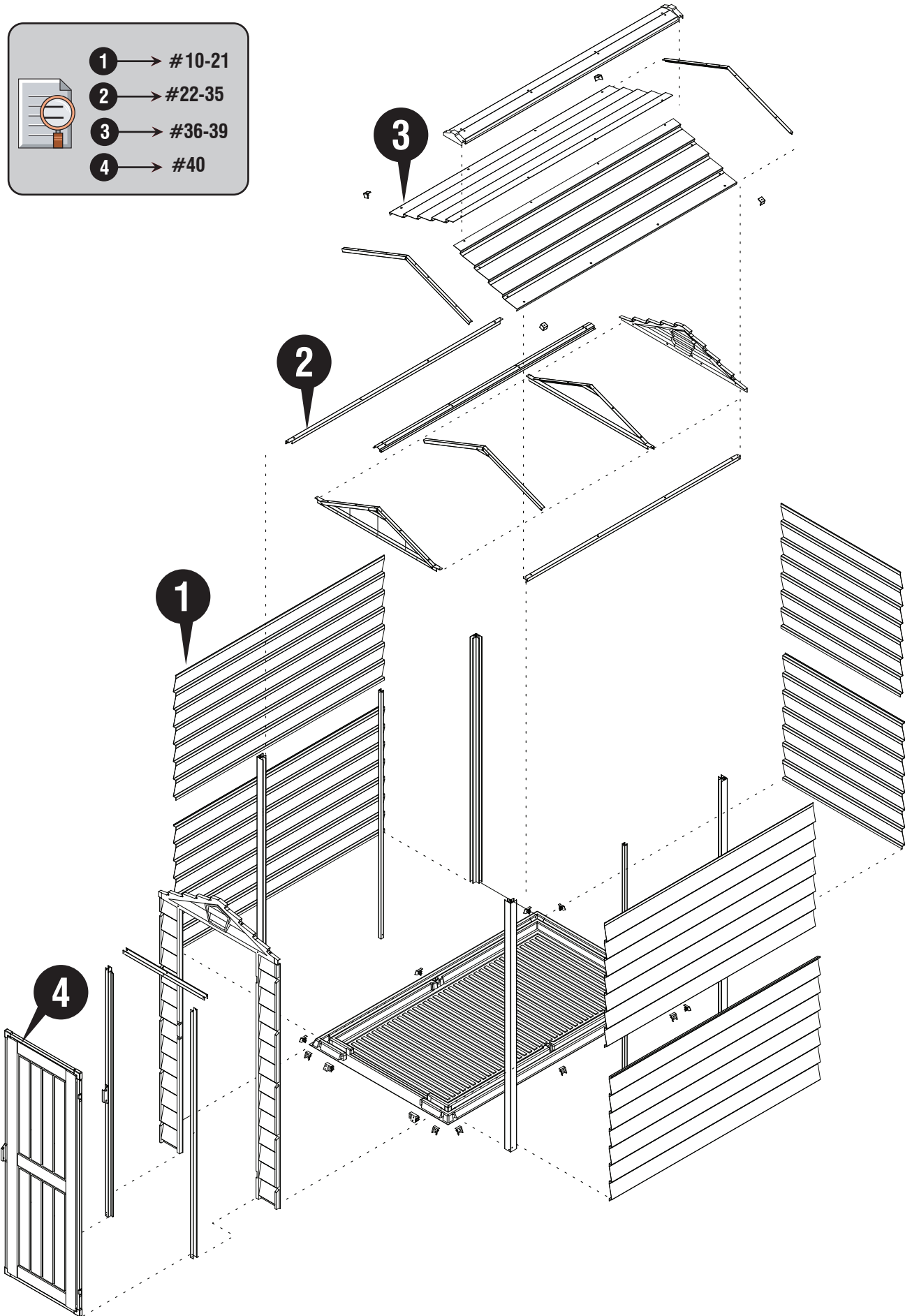



<b>EN</b> Pre-Assembly	<b>CS</b> Předmontáž	<b>IT</b> Pre assemblato
<b>FR</b> Pré-assemblée	<b>SK</b> Pre-Zostava	<b>PL</b> Przedmontaż
<b>DE</b> Vormontage	<b>SL</b> Predskupina	<b>RO</b> Pre asamblat
<b>ES</b> Preasamblea	<b>HR</b> Pre-Montaža	<b>BG</b> Предварително събиране
<b>PT</b> Pré Assembléia	<b>HU</b> Pre-Assembly	<b>TR</b> Ön montaj
<b>NL</b> Voorgemonteerd	<b>SV</b> Färdigmonterad	

**1**

- EN** 1. Set the Torque limit of your Screw drill to #1 - #4 to ensure the Screws do not strip the Metal reinforcements.  
2. It is important that these instructions are followed step by step.  
3. Don't install under windy conditions.  
4. All parts are clearly marked and care should be taken to use the correct one.  
5. If you are building the shed against a wall, build it 2.5 ft. away then slide it in. (Only for Duramax foundation & Wooden foundation)

- FR** 1. Réglez la limite de couple de votre perceuse Vis à n # 1 - # 4 pour s'assurer que les vis ne supprime pas les renforts métalliques.  
2. Il est important que ces instructions soient suivies pas à pas.  
3. Ne pas installer sous conditions de vent.  
4. Toutes les pièces sont clairement identifiées et il convient de veiller à utiliser la bonne.  
5. Si vous construisez le hangar contre un mur, le construire à un écart de 2,5 pi, puis le glisser. (ceci n'est applicable pour la Fondation Duramax Fondation en bois).

- DE** 1. Stellen Sie die Torque Limit Ihres Schraube Bohrer # 1 - # 4, um die Schrauben sicher nicht stripfen die Metallverstärkung.  
2. Diese Anleitung muss unbedingt Schritt für Schritt befolgt werden.  
3. Die Montage nicht bei windigem Wetter vornehmen.  
4. Alle Teile sind deutlich gekennzeichnet und es ist darauf zu achten, dass die richtige verwendet wird.  
5. Wenn Sie den Schuppen an einer Wand bauen, bauen sie es 2,5 Fuß weg, dann schieben Sie es ein. (Nur für Duramax Fundament & Holzfundament)

- ES** 1. Establecer el límite de par de su taladro tornillo de # 1 - # 4 para asegurar los tornillos no tira los refuerzos metálicos.  
2. es importante que estas instrucciones se sigan paso a paso.  
3. No instale las condiciones abajo de mucho viento.  
4. Todo pone piezas son marcados claramente y cuidan debe ser tomado para usar el orrigo uno.  
5. Si usted está construyendo la cubierta contra una pared, construirlo 2.5 pies de distancia y deslízela hacia dentro. (esto sólo es aplicable para la Fundación de Duramax Fundación madera).

- PT** 1. Defina o limite de Torque de sua broca parafuso para # 1 - # 4 para garantir que os parafusos não tira os reforços de metal.  
2. É importante que estas instruções sejam seguidas passo a passo.  
3. Não instale sob condições com forças ventanosas.  
4. Todas as peças estão claramente marcadas e deve-se tomar cuidado para usar a correta.  
5. Se você está construindo o galpão contra uma parede, construa-o a 2,5 pés de distância para então encostá-lo na mesma. (Apenas para o Duramax fundação e base de madeira)

- NL** 1. Stel de Torque limiet van uw Schroef boormachine op # 1 - # 4 om de schroeven zorgen niet strip de Metal versterkingen.  
2. Het is belangrijk dat volgende instructies stap voor stap worden gerespecteerd.  
3. Nooit de schuur installeren onder winderige omstandigheden.  
4. Alle onderdelen zijn duidelijk gemarkeerd en er moet op worden gelet dat de juiste wordt gebruikt.  
5. Als u het schuur tegen muur aan het bouwen bent, bouw u maar de schuur op 70cm afstand en schuif die er tegen de muur aan. (Alleen voor Duramax foundation & Houten foundation)

- CS** 1. Nastavte mezní hodnotu točivého momentu vrtacího vrtáku na #1 - #4, abyste zajistili, že šrouby neztáhnou kovové výztuhy.  
2. Je důležité aby jste tento návod sledovali krok za krokem.  
3. Nemontujte při větrném počasí.  
4. Všechny díly jsou jasně označeny a je třeba dbát na správnou funkci.  
5. Pokud stavíte přístřešek proti zdi, postavte jí 70cm stranou a poté jí přisuňte. (Pouze pro Duramax založení a dřevěné základy)

- SK** 1. Nastavte limit krútiaceho momentu vŕtacieho vŕtáka na #1 - #4, aby ste zaistili, že skrutky nezaberajú kovové výztuhy.  
2. Je nutné dodržiavať tieto inštrukcie krok za krokom.  
3. Neinštalujte za veterných podmienok.  
4. Všetky časti sú zreteľne označené a treba dbať na to, aby boli použité správne.  
5. Ak budujete múru, postavte ju 2,5 stôp. preč, a potom ju zasunúť. (Len pre Duramax založenie a drevené základy)

- SL** 1.Za omejitev vrtilnega momenta vijáčnega vijaka nastavite #1 - #4, da zagotovite, da vijaki ne ojačitijo kovinskih ojačitev .  
2.Pomembno je, da sledite opisanim navodilom korak za korakom.  
3.Montaže ne izvijajte, kadar piha močen veter.  
4.Vsi deli so jasno označeni in pazite na pravilno uporabo.  
5.Če se gradi skladišče proti steni, ga graditi 2,5 ft. stran, nato pa ga potisnite v. (samo za Duramax temelj in leseno osnovo)

- HR** 1.Postavite granicu zakretnog momenta Vašeg vijčanog bušilica na #1 - #4 kako biste osigurali da vijci ne skidaju metalna po jačanja.  
2.To je važno da ovih instrukcije su slijedili korak po korak.  
3.Nemojte instalirati pod vjetrovitim uvjetima.  
4.Svi dijelovi su jasno označeni i treba voditi brigu o ispravnom korištenju.  
5.Ako gradite proliveno zid, izgradite ga 2,5 m. daleko, a zatim ga gurnite. (Samo za Duramax zaklade i drveni temelja)

- HU** 1.Állítsa a csavarhúzó nyomatékhatárait #1 - #4-re, hogy a csavarok ne csavarják le a fém vasalásokat  
2.Fontos, hogy az itt következő instrukciókat lépésről lépésre betartsa.  
3.Szeles időben ne végezzen összeszerelést.  
4.Minden alkatrész egyértelműen megjelölve, és gondoskodni kell a helyes használatáról.  
5.Ha egy fészket építesz a falhoz, építsd meg 2,5 métert. távolítsa el, majd csúsztassa be. (Csak a Duramax Alapítvány és a Fa Alapítvány)

- SV** 1.Ställ in momentskraven på din skruvborr till #1 - #4 för att säkerställa att skruvarna inte slår av metallförstärkningarna.  
2.Det är viktigt att dessa instruktioner följs steg för steg.  
3.Installera inte när det är blåsigt.  
4.Alla delar är tydligt märkta och försiktighet bör vidtas för att använda rätt.  
5.Om du bygger ett skjul mot en vägg, bygg det 2,5 ft. bort och skjut in den. (Endast för Duramax Foundation & Wooden stiftelse)

- IT** 1. Impostare il limite di coppia della fresa a vite a #1 - #4 per assicurare che le viti non striscia i rinforzi metallici  
2.E' molto importante che queste istruzioni vengano seguite passo dopo passo.  
3.Non installare in presenza di forte vento.  
4.Tutte le parti sono chiaramente contrassegnate e occorre prestare attenzione per utilizzare quella corretta.  
5.Se si sta costruendo il capannone contro un muro, costruirlo 2,5 ft. via, poi farlo scorrere in. (Solo per Duramax Foundation e Fondazione di legno)

- PL** 1.Zestaw limit momentu obrotowego twój śruby wierceń do #1 - #4, aby upewnić się, że śruby nie taśmy wzmocnień  
2.Bardzo ważne jest, by dokładnie stosować się do niniejszej instrukcji.  
3.Nie należy montować w przypadku silnego wiatru.  
4.Wszystkie części są wyraźnie oznaczone i należy zachować ostrożność, aby użyć właściwego.  
5.Jeśli budujesz szopę przy ścianie, buduj ją 2,5 stopy dalej, a następnie wsuń ją.(Tylko do fundamentu Duramax i drewnianego fundamentu).

- RO** 1.Setați limita de cuplu a burghiului dvs. de șurub la #1 - #4 pentru a vă asigura că șuruburile nu lărgește armăturile metalice.  
2.Este importantă respectarea pas cu pas a acestor instrucțiuni.  
3.Nu instalați dacă vântul atinge viteze mari.  
4.Toate părțile sunt marcate în mod clar și trebuie să se țină seama de utilizarea celei corecte.  
5.Dacă construiți vaporeșul pe perete, construiți-l la o distanță de 2,5 ft, apoi glisați-l. (Doar pentru fundația Duramax & fundație din lemn)

- BG** 1.Нагласете границата на въртящия момент на винтовата витла до #1 - #4, за да се уверите, че винтовете не изрязват металните подсилвания.  
2.Важно е да следвате инструкциите стъпка по стъпка.  
3.Да не се монтира при ветровито време.  
4.Всички части са ясно маркирани и трябва да се внимава да се използва правилната.  
5.Ако сте изградане на навес срещу стена, изградане то на 2,5 фута далеч след това го плъзнете инча (Само за Duramax фондация & дървени основи)

- TR** 1.Vidaların Metal takviyeleri soymadığından emin olmak için Vidalı matkabınızın Moment sınırını #1 - #4'e ayarlayın.  
2.Talimatların sırasıyla uygulanması önemlidir.  
3.Rüzgarlı havalarda kurmayınız.  
4.Tüm parçalar açıkça işaretlenmiştir ve doğru olanı kullanmak için özen gösterilmelidir.  
5.Bir duvara kulübe bina varsa, o 2.5 ft kurmak. uzakta bir biçimde kaydırın. (Yalnızca Duramax vakıf ve Ahşap vakıf için)



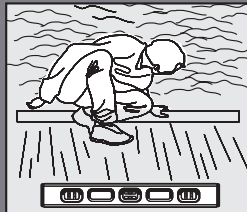

(EN) DuraMax must be installed on a DuraMax Foundation, level wooden platform or a level concrete foundation, that has an outside dimension of 47 1/4" x 75" (1199mm x 1905mm).

(FR) DuraMax doit être installé sur une plate-forme en bois de niveau ou une fondation en béton de niveau, qui a une dimension extérieure de 47 1/4" x 75" (1199mm x 1905mm).

(DE) Duramax muss auf einer ebenen Holzplattform oder einem ebenen Betonfundament mit einer Außenabmessung von 47 1/4" x 75" (1199mm x 1905mm) installiert werden.

(ES) DuraMax debe instalarse en una plataforma de madera nivelada o una base de hormigón nivelada, que tenga una dimensión exterior de 47 1/4" x 75" (1199mm x 1905mm).

(PT) Duramax deve ser instalado em uma base Duramax, plataforma de madeira de nível ou uma base de concreto nivelada, que tem uma dimensão externa de 47 1/4" x 75" (1199mm x 1905mm).

(NL) Duramax moet geïnstalleerd worden op een Duramax foundation, level houten platform of een betonconcreet, dat heeft een externe dimensie van 47 1/4" x 75" (1199mm x 1905mm).

(CS) Duramax musí být instalován na základně Duramax, dřevěnou plošinu nebo rovinnou základovou konstrukci, který má vnější rozměr 47 1/4" x 75" (1199mm x 1905mm).

(SK) Firma Duramax musí byť inštalovaná na základni Duramax, na drevenej plošine alebo na úrovni betónu, ktorý má vonkajší rozmer 47 1/4" x 75" (1199mm x 1905mm).

(SL) Duramax mora biti nameščen na temelju Duramax, ravne lesene ploščadi ali ravne betonske podlage, ki ima zunanjo dimenzijo 47 1/4" x 75" (1199mm x 1905mm).

(HR) Duramax mora biti instaliran na temeljima Duramax, drvenoj platformi ili razini konkretnog betona, koji ima vanjsku dimenziju od 47 1/4" x 75" (1199mm x 1905mm).

(HU) A Duramax-ot Duramax alapra, szintetikus fapadróra vagy szintetikus betonra kell telepíteni, amelynek külső mérete 47 1/4" x 75" (1199mm x 1905mm).

(SV) Duramax måste installeras på en Duramax-grund, en plan träplattform eller en jämn betongfundament, som har en yttre dimension av 47 1/4" x 75" (1199mm x 1905mm).

(IT) Duramax deve essere installato su una base Duramax, una piattaforma di legno a livello o una base di calcestruzzo a livello, che ha una dimensione esterna di 47 1/4" x 75" (1199mm x 1905mm).

(PL) DuraMax musi być zainstalowany na poziomej drewnianej platformie lub poziomym fundamencie betonowym o wymiarze zewn. trzymym 47 1/4" x 75" (1199mm x 1905mm).

(RO) Duramax trebuie instalat pe o fundație Duramax, platformă de lemn de nivel sau fundație de beton, care are o dimensiune exterioară de 47 1/4" x 75" (1199mm x 1905mm).

(BG) Duramax трябва да се монтира на основата на Duramax, дървена платформа на нивото или на бетонна основа, който има външно измерение 47 1/4" x 75" (1199mm x 1905mm).

(TR) Duramax, bir Duramax vakfı, düz ahşap platform veya düz bir beton temel üzerine kurulmalıdır, dış çapı 47 1/4" x 75" (1199mm x 1905mm).

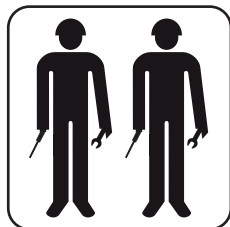

EN Two people needed.

FR Deux personnes nécessaires.

DE Zwei Personen benötigt.

ES Dos personas son necesarias para el montaje.

PT Duas pessoas necessárias.

NL Er zijn twee mensen nodig.

CS Dva lidé potřebovali.

SK Dvaja ľudia potrebovali.

SL Potrebovali sta dve osebi.

HR Potrebne su dvije osobe.

HU Két emberre volt szükség.

SV Två personer behövd.

IT Sono necessarie due persone.

PL Potrzebne są dwie osoby.

RO Au nevoie de doi oameni.

BG Нужни са двама души.

TR İki kişiye ihtiyaç vardı.

EN	Parts needed	CS	Potřebné součásti	IT	Parti occorrenti
FR	Pièces nécessaires	SK	Potrebné časti	PL	Niezbędne elementy
DE	Benötigte Teile	SL	Dele, ki jih boste potrebovali	RO	Elementele componente necesare
ES	Las partes necesarias	HR	Dijelovi potreban	BG	Необходими части
PT	Peças Necessárias	HU	Szükséges részek	TR	Gerekli parçalar
NL	Onderdelen nodig	SV	Delar som behövs		

SPH1	2	VRH06	2
SPH2	2	VRH07	1
VCH01	1	VRH08	1
VCH02	1	VRH09	1
VRH02	1	CCH1	4
VRH03	1	S1	20
VRH04	2	S7	11
VRH05	2	SAC1	6

1

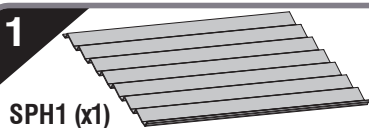

VCH02 (x1)



SAC1 (x1)

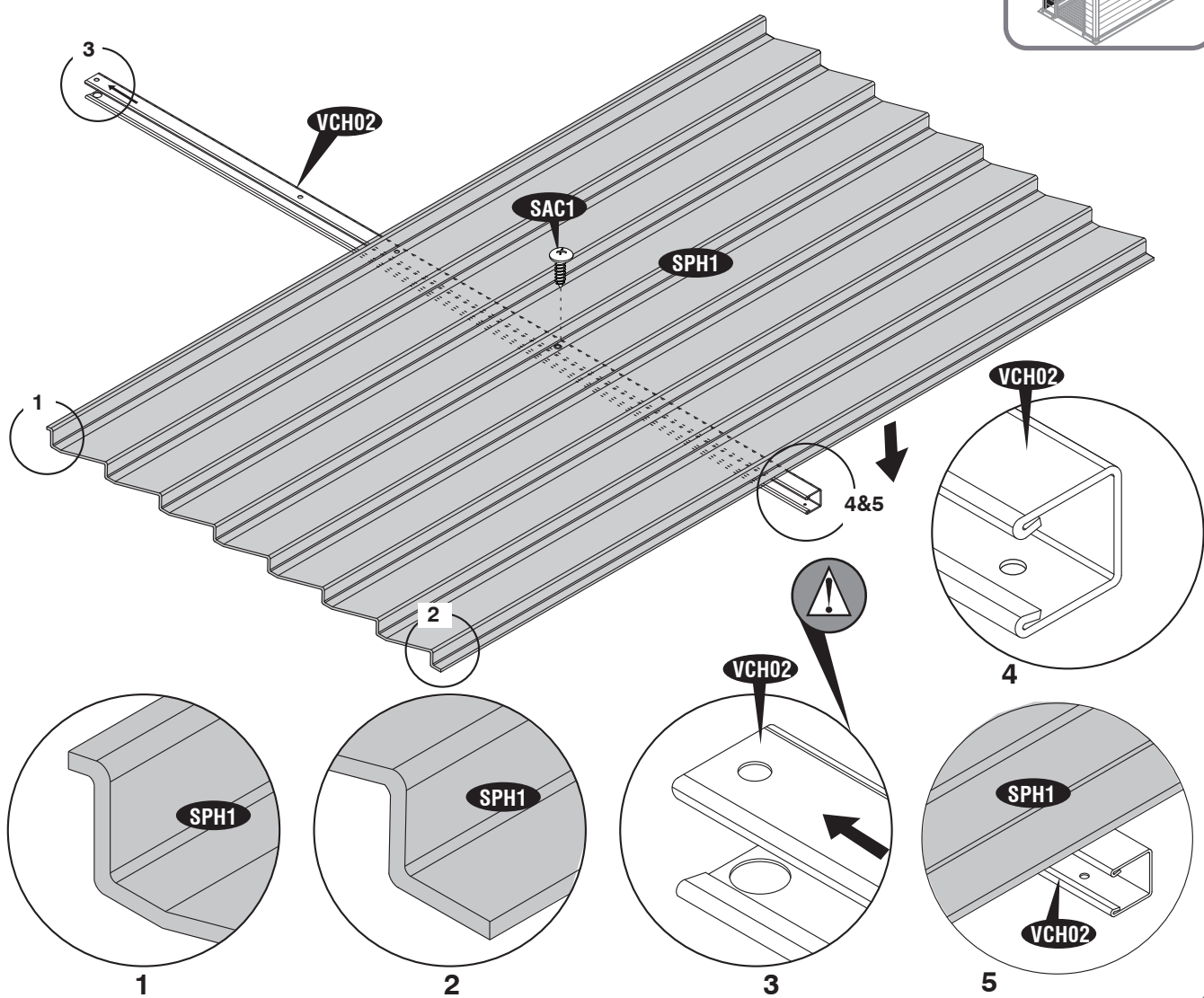
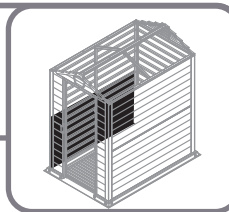



SPH2 (x1)



SAC1 (x2)

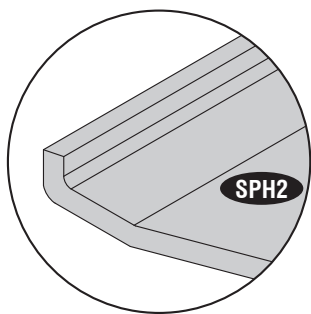
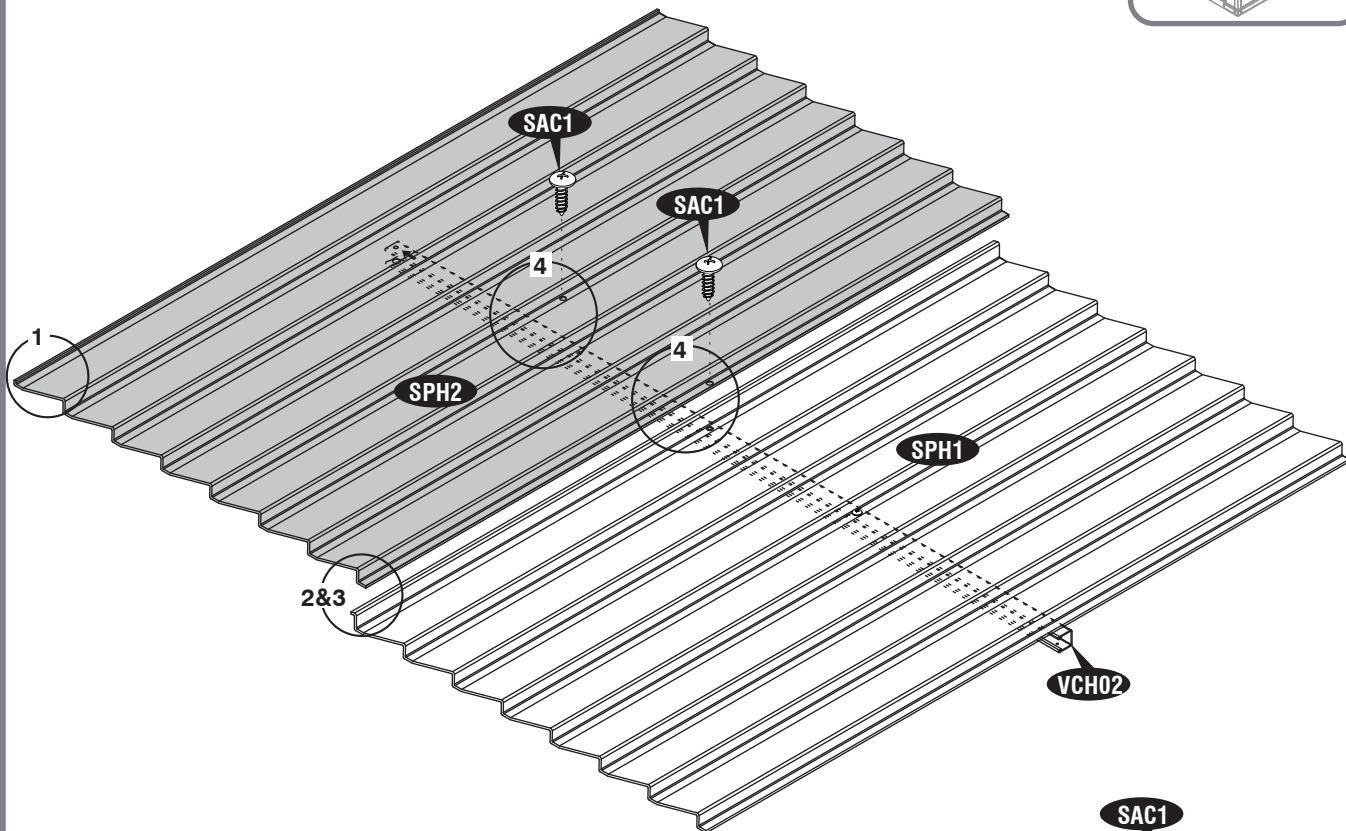
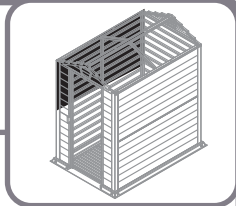

1

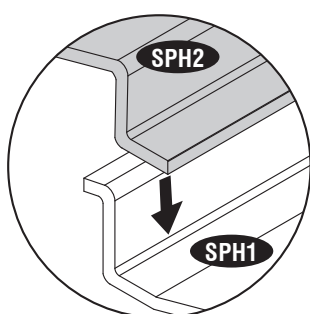

2

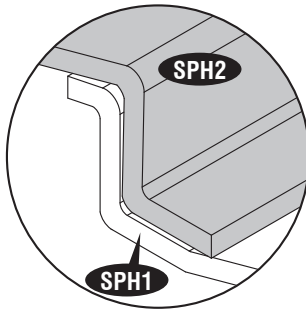

3

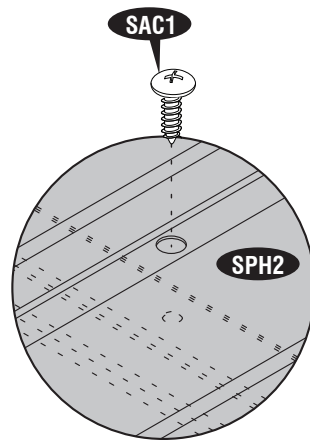

4

3

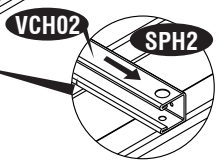
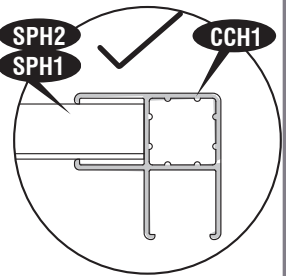
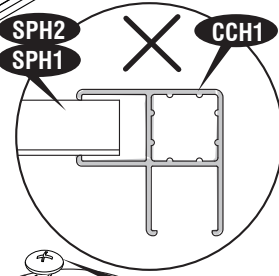
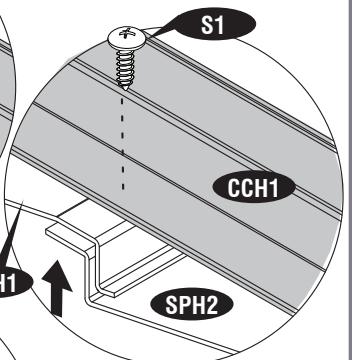
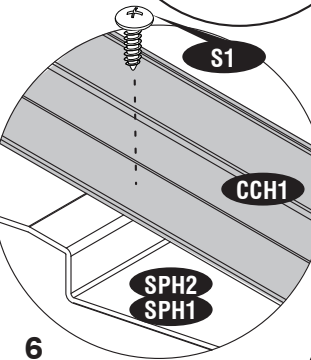
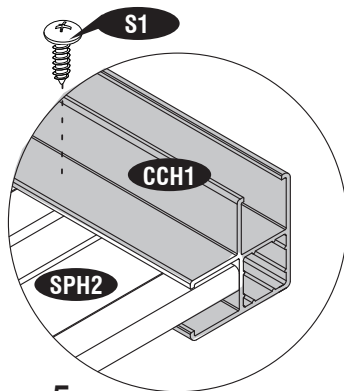
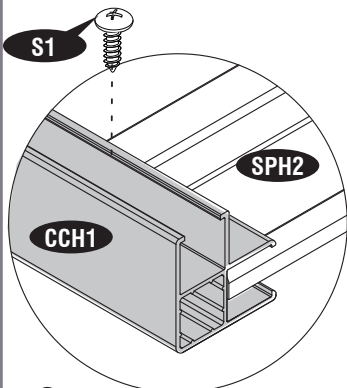
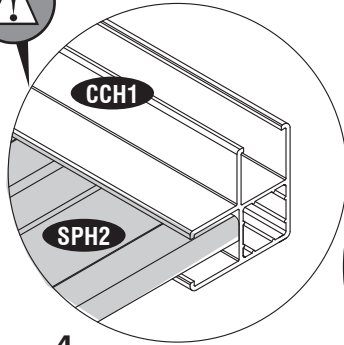
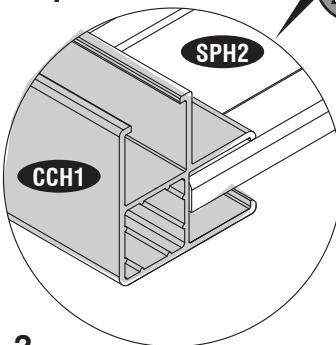
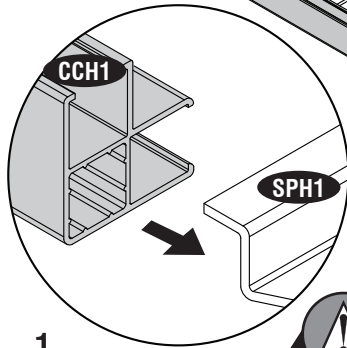
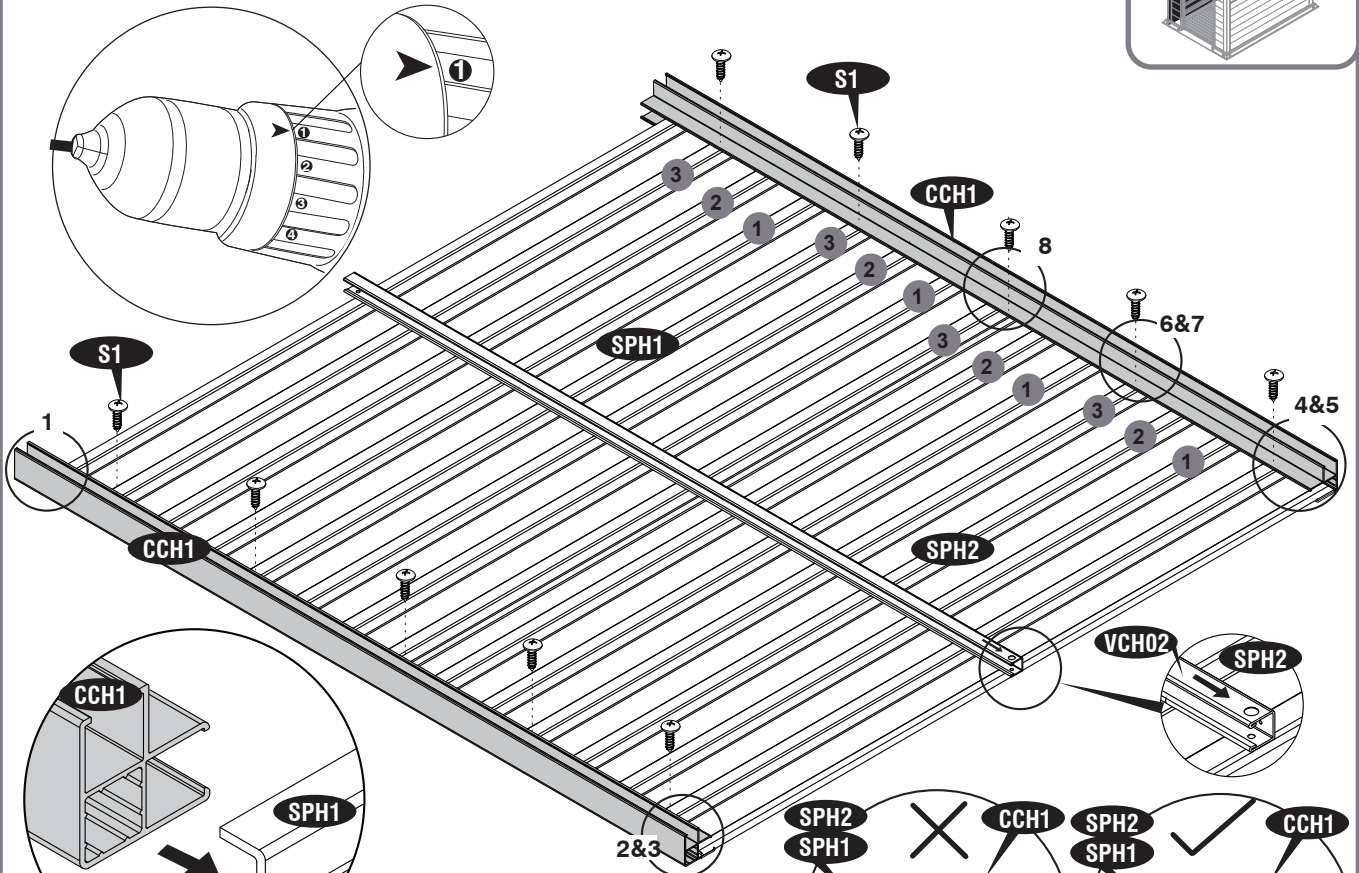
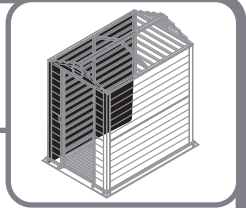
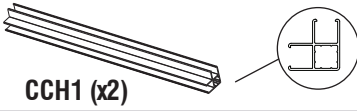



4

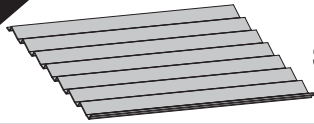

SPH1 (x1)



VCH01 (x1)



SAC1 (x1)

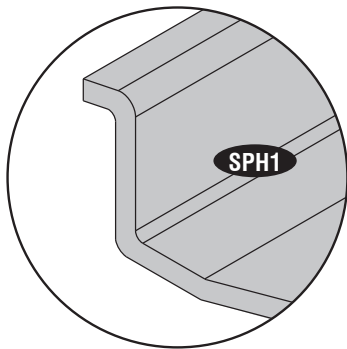
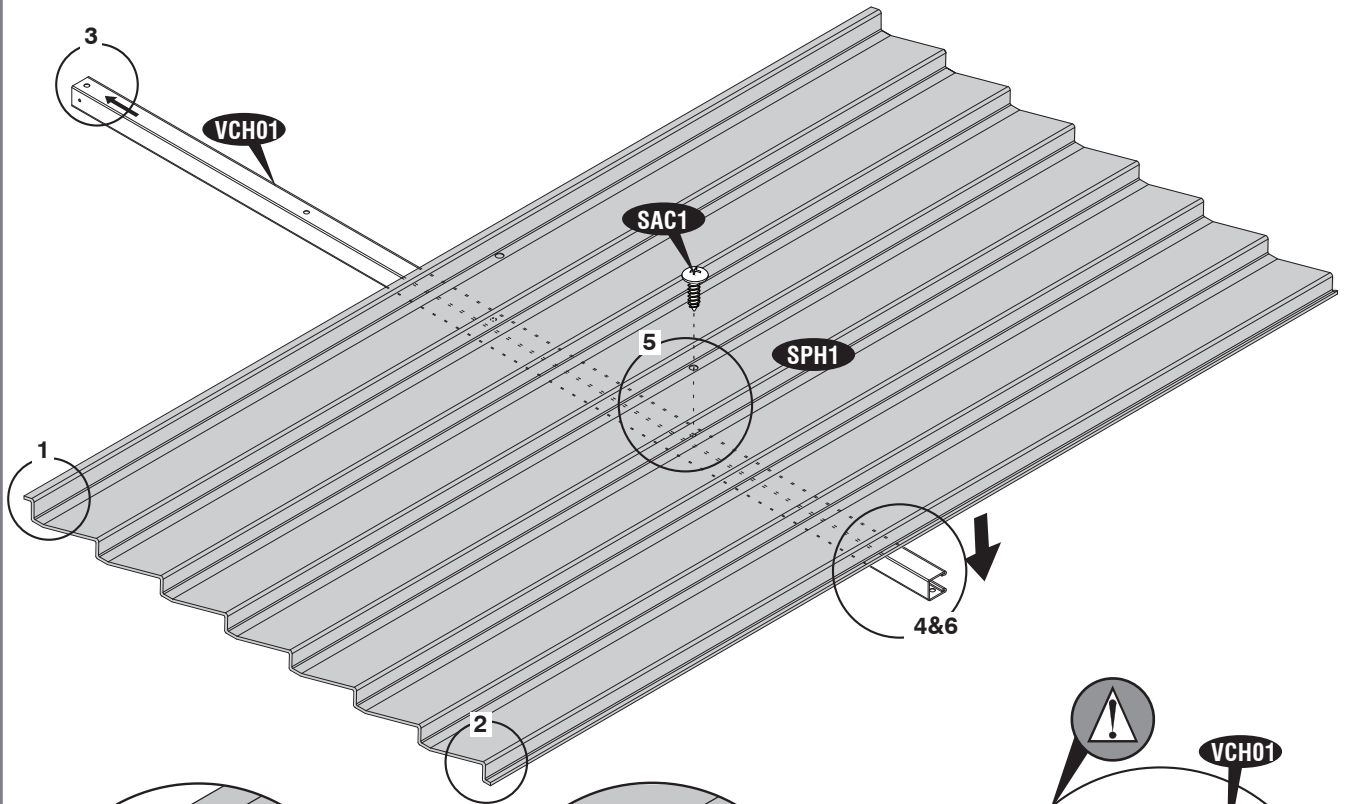
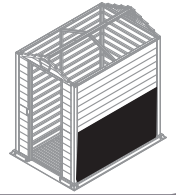

1

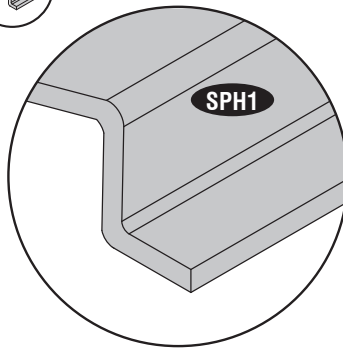

2

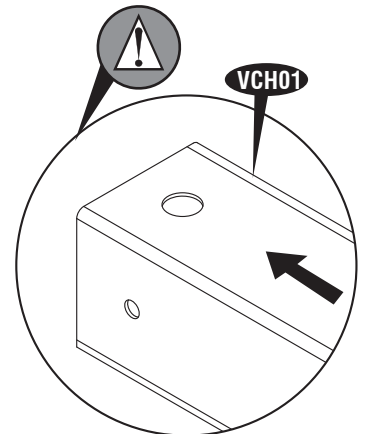

3

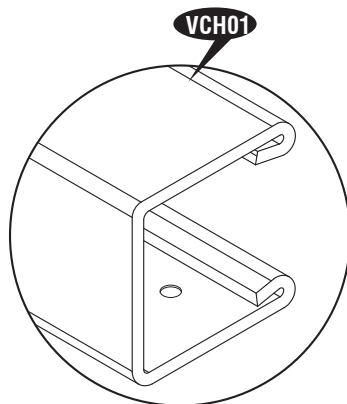

4

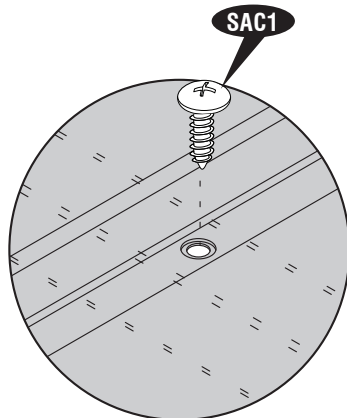

5

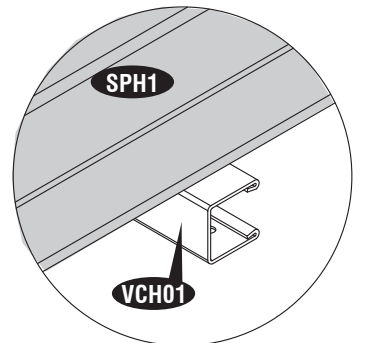

6

5



SPH2 (x1)



SAC1 (x2)

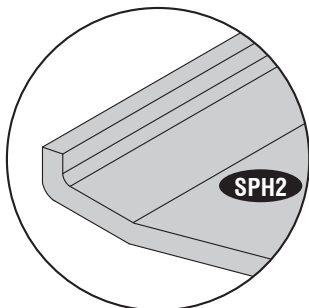
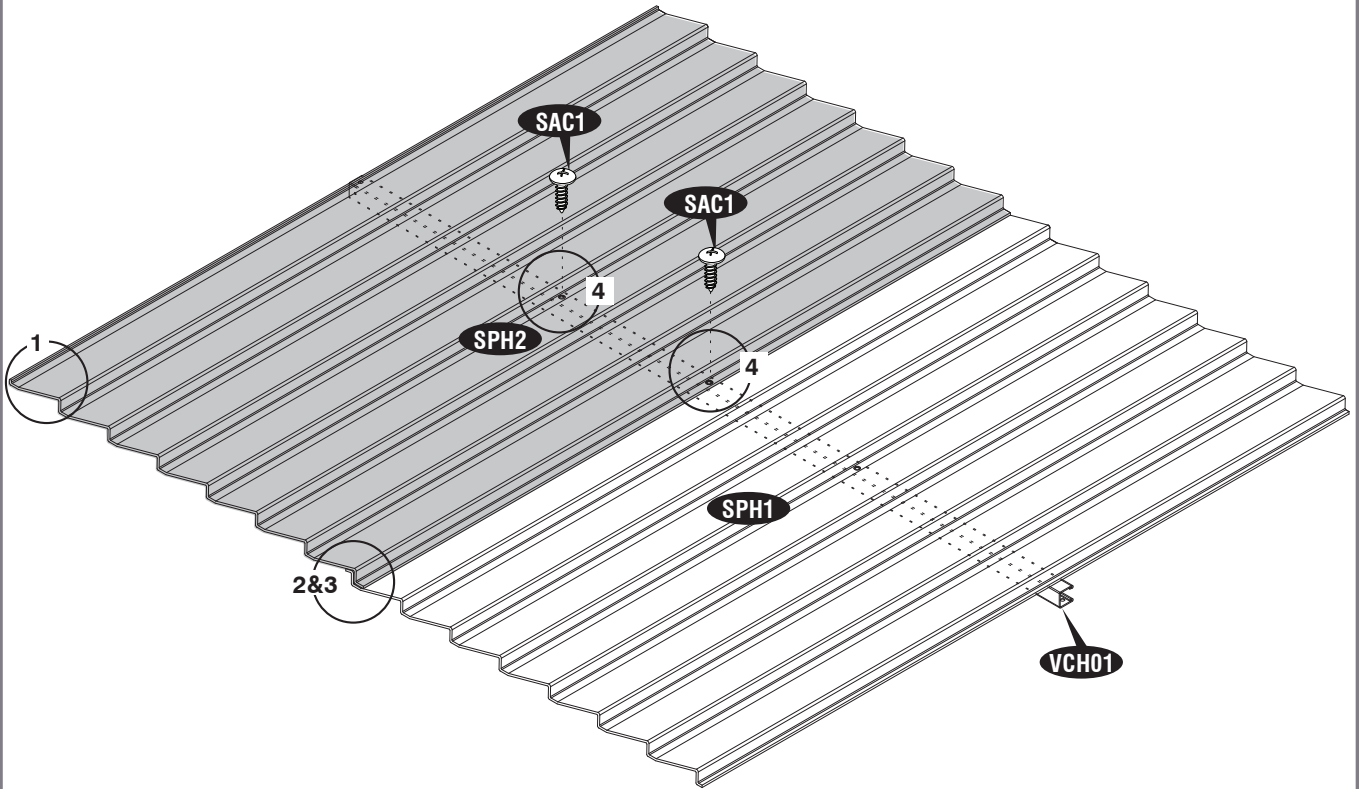
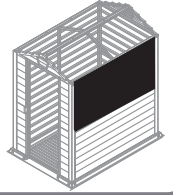

1

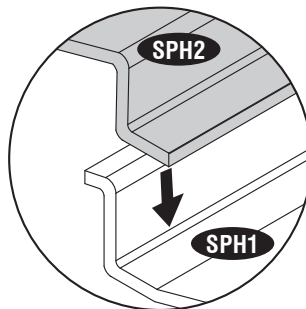

2

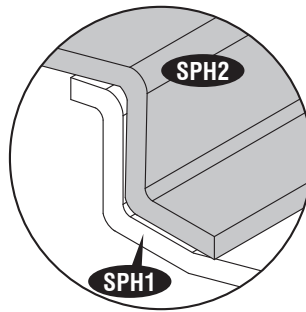

3

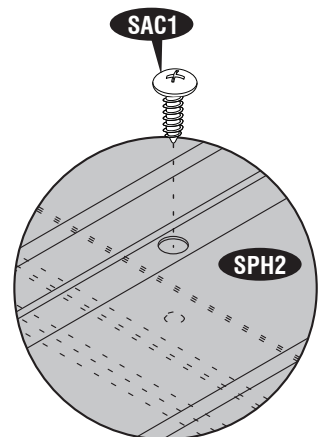

4

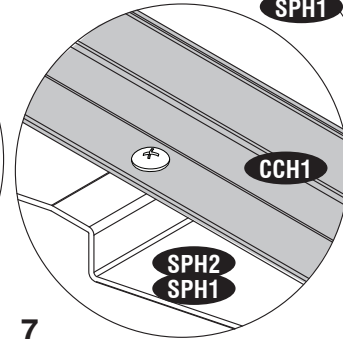
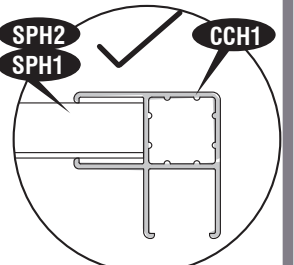
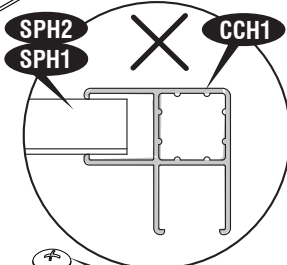
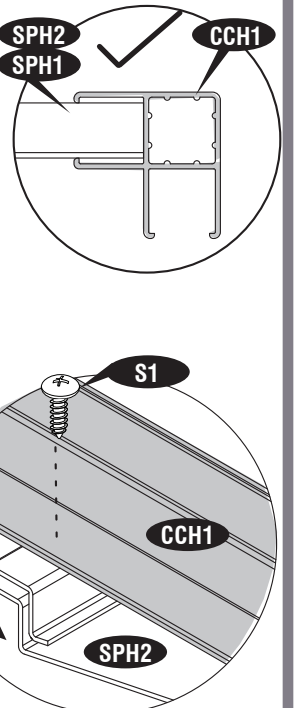
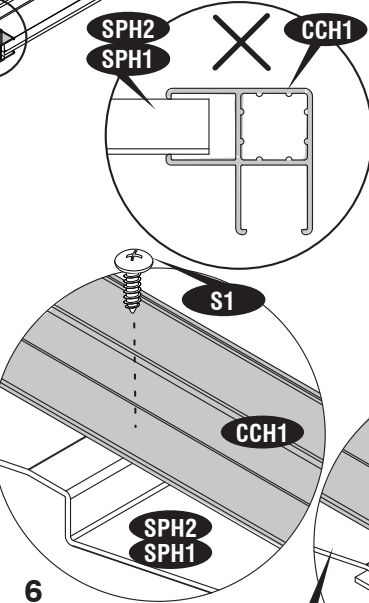
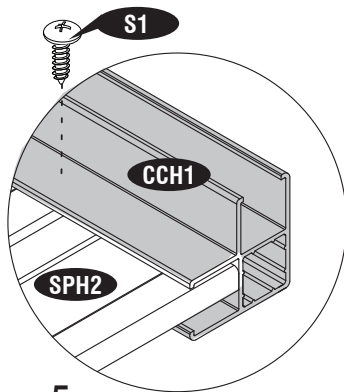
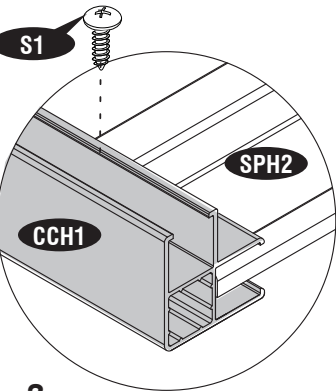
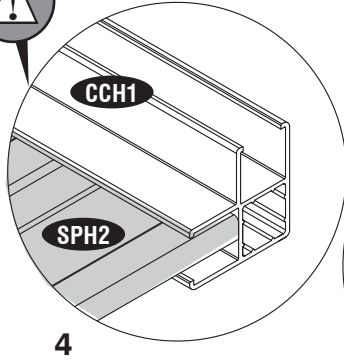
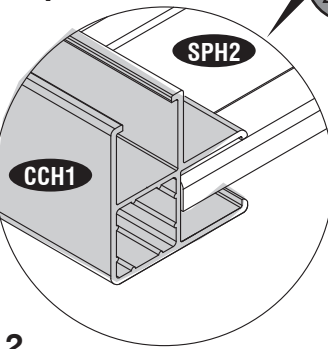
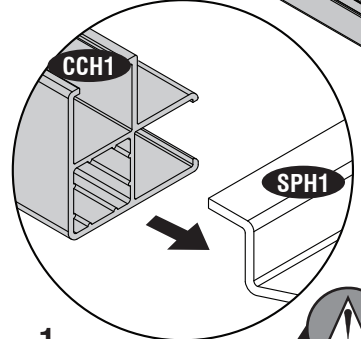
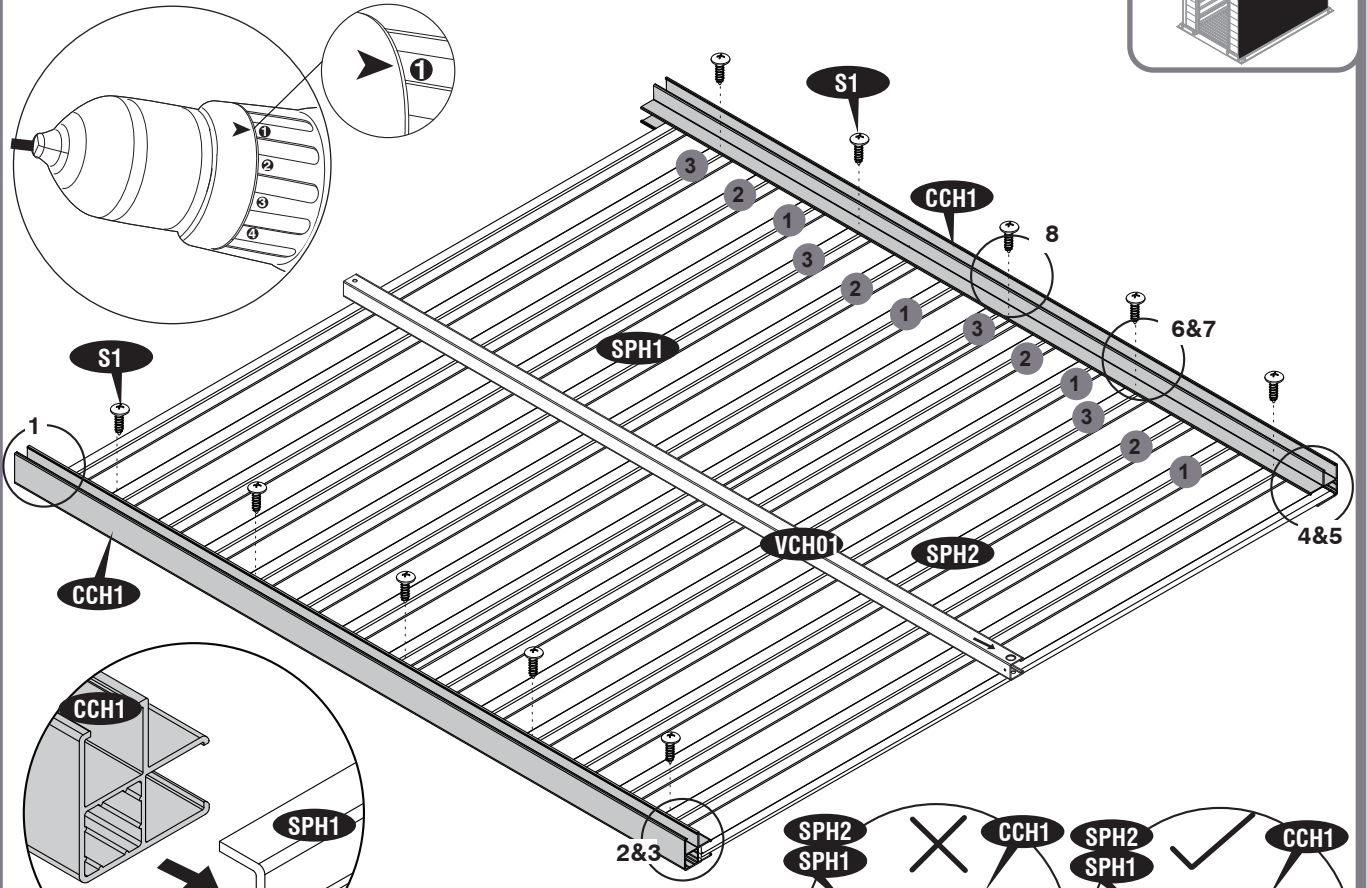
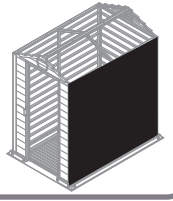

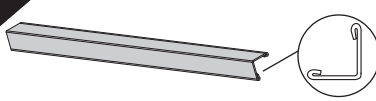

VRH04 (x1)  
VRH05 (x1)  
VRH06 (x1)

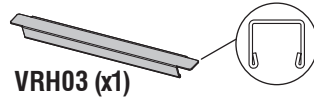

VRH03 (x1)

S7 (x5)

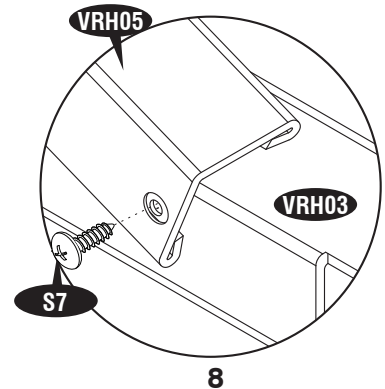
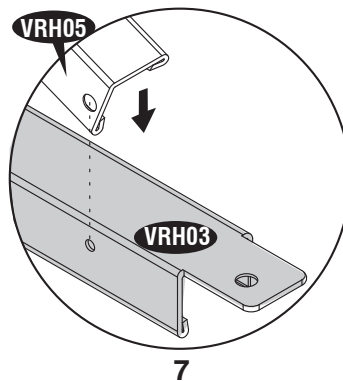
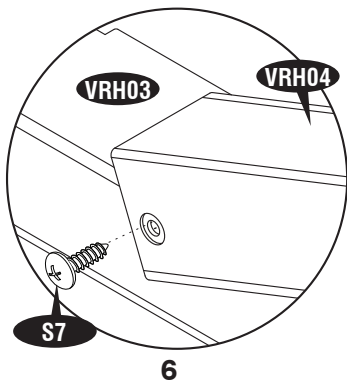
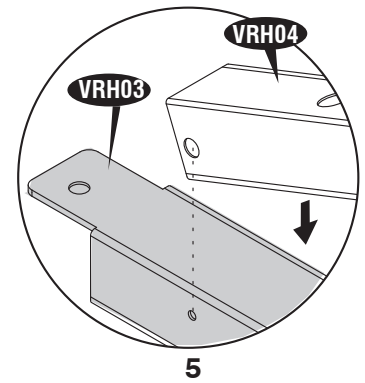
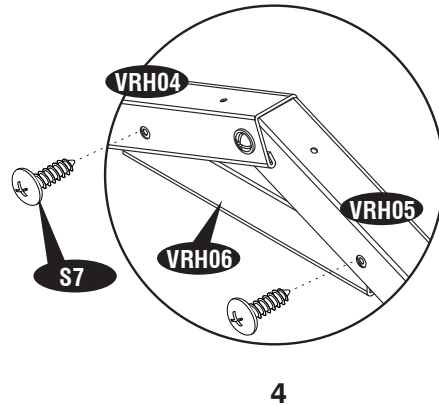
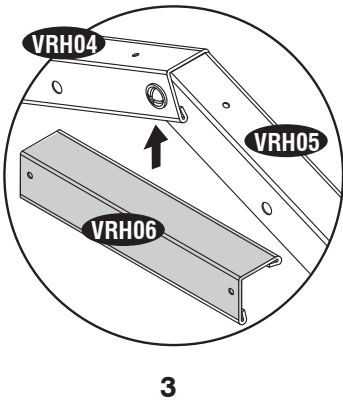
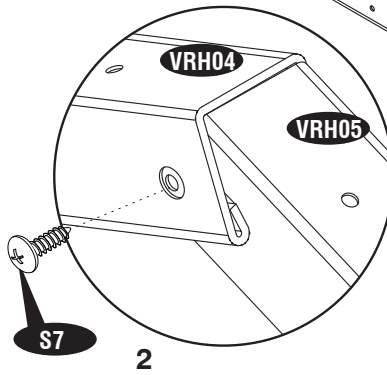
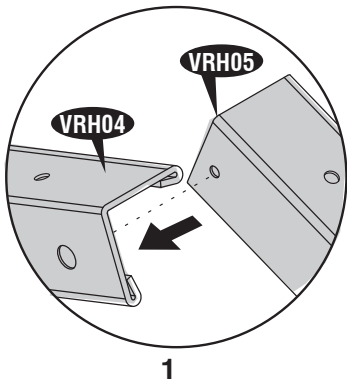
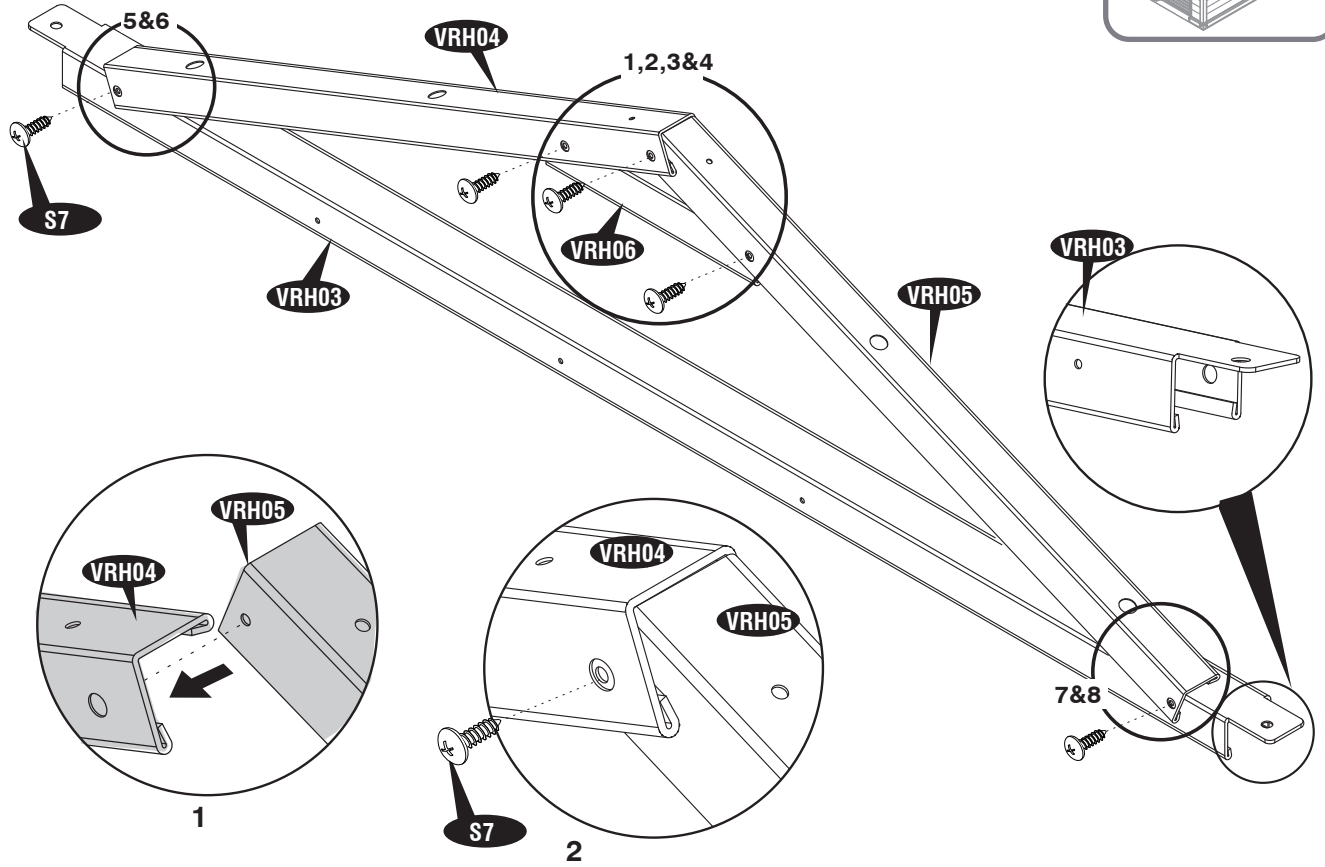
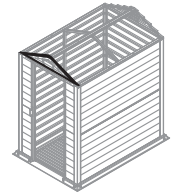

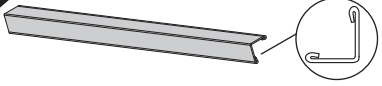

VRH04 (x1)  
VRH05 (x1)  
VRH06 (x1)

S7 (x3)

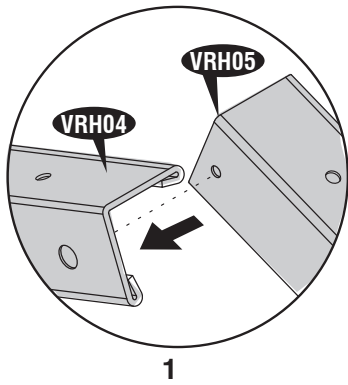
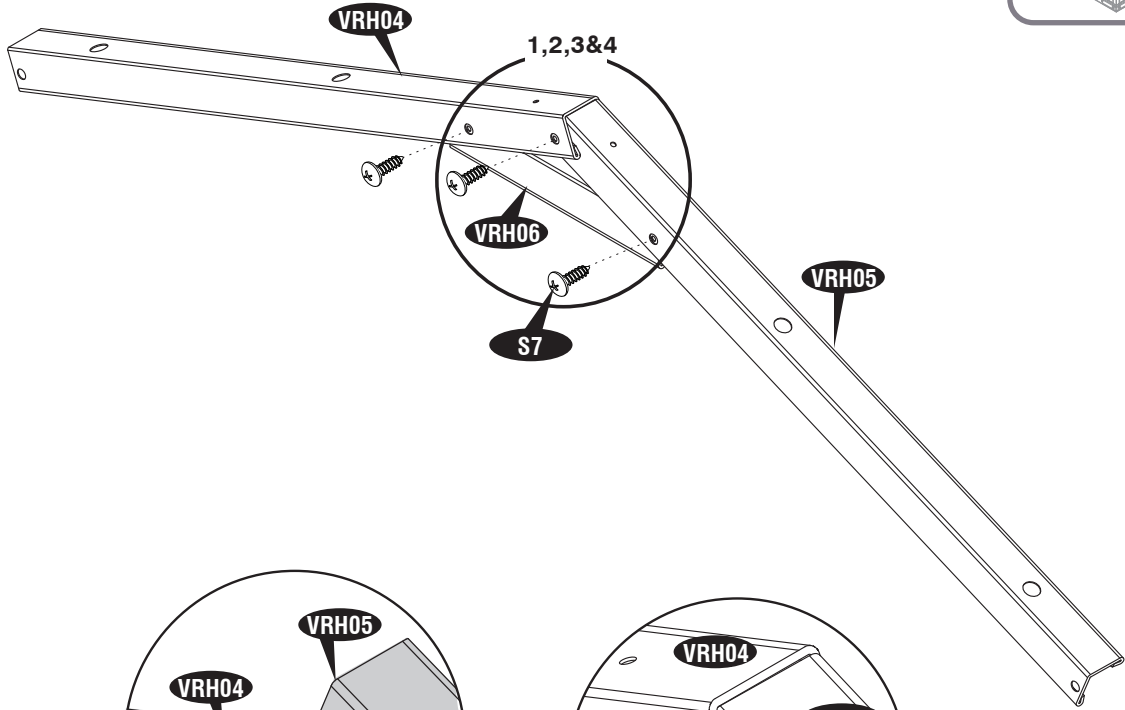
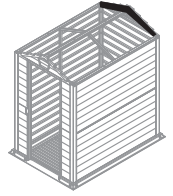

1

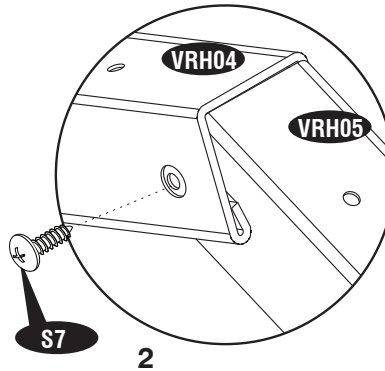

2

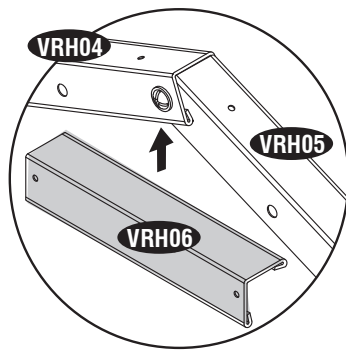

3

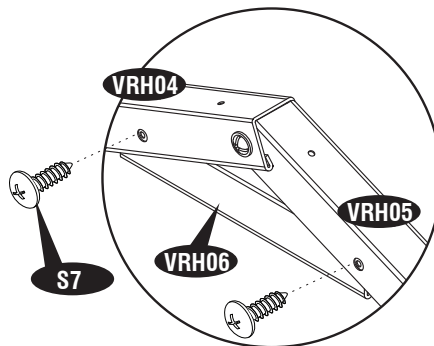

4

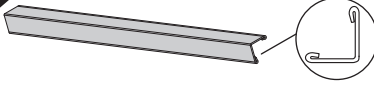

VRH07 (x1)  
VRH08 (x1)  
VRH09 (x1)

S7 (x3)

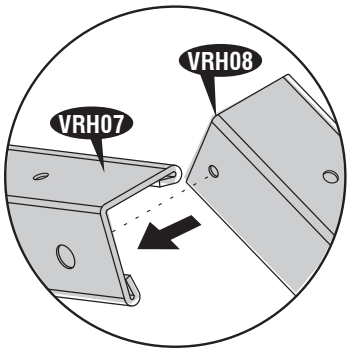
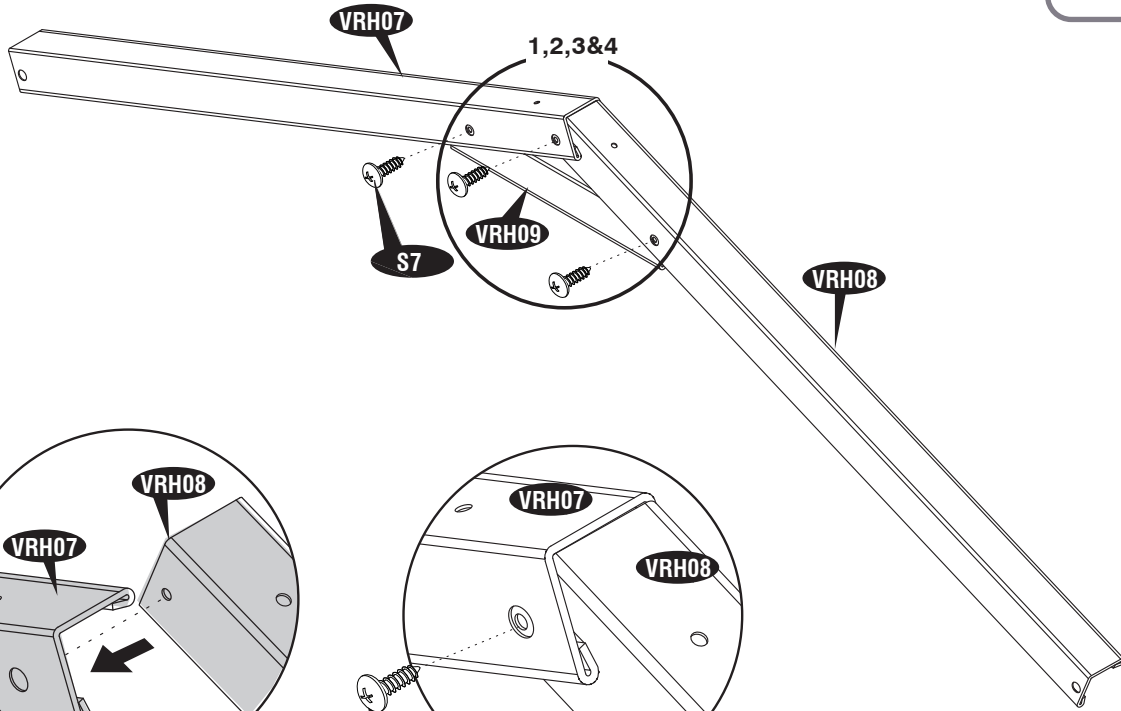
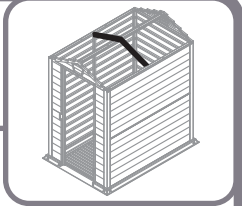

1

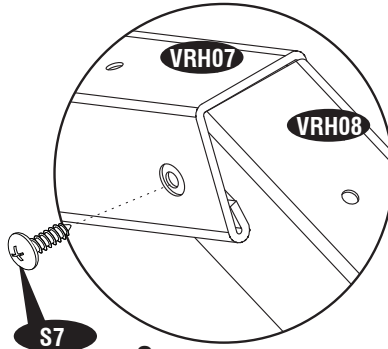

2

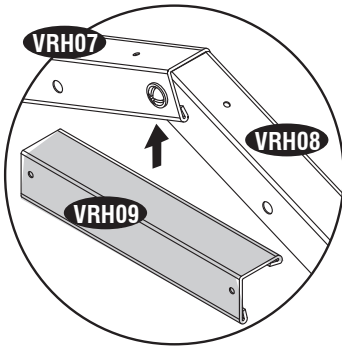

3

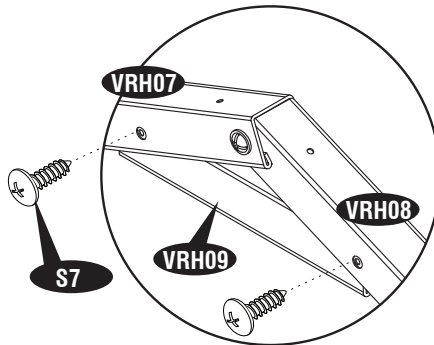

4





- 2**
- |                               |                      |                        |
|-------------------------------|----------------------|------------------------|
| EN Walls & columns            | CS Zdi a kolumny     | IT Pareti & Colonne    |
| FR Murs et colonnes           | SK Steny a stĺpy     | PL Ściany i Kolumny    |
| DE Wände und Säulen           | SL Stene in stebri   | RO Pereți și stâlpi    |
| ES Las paredes & las Columnas | HR Zidovi i Kolumne  | BG Стени & Колони      |
| PT Paredes e Colunas          | HU Falak és oszlopok | TR Duvarlar & Sütunlar |
| NL Panelen en stijlen         | SV Väggar & Kolumner |                        |

- |                          |                                   |                                   |
|--------------------------|-----------------------------------|-----------------------------------|
| EN Parts needed          | CS Potřebné součásti              | IT Parti occorrenti               |
| FR Pièces nécessaires    | SK Potřebné části                 | PL Niezbędne elementy             |
| DE Benötigte Teile       | SL Dele, ki jih boste potrebovali | RO Elementele componente necesare |
| ES Las partes necesarias | HR Dijelovi potreban              | BG Необходими части               |
| PT Peças Necessárias     | HU Szükséges részek               | TR Gerekli parçalar               |
| NL Onderdelen nodig      | SV Delar som behövs               |                                   |

BPH1	1	BCRR	10
SPH3	1	BFRT	1
SPH4	1	BFLT	1
SPH5	1	BP	6
VRH01	2	S1	31
VRH10	1	S7	16
VDRH	1	SGC1	3
VDLH	1	S5	14
VDTH	1	S6	14



**1**



**BPH1 (x1)**

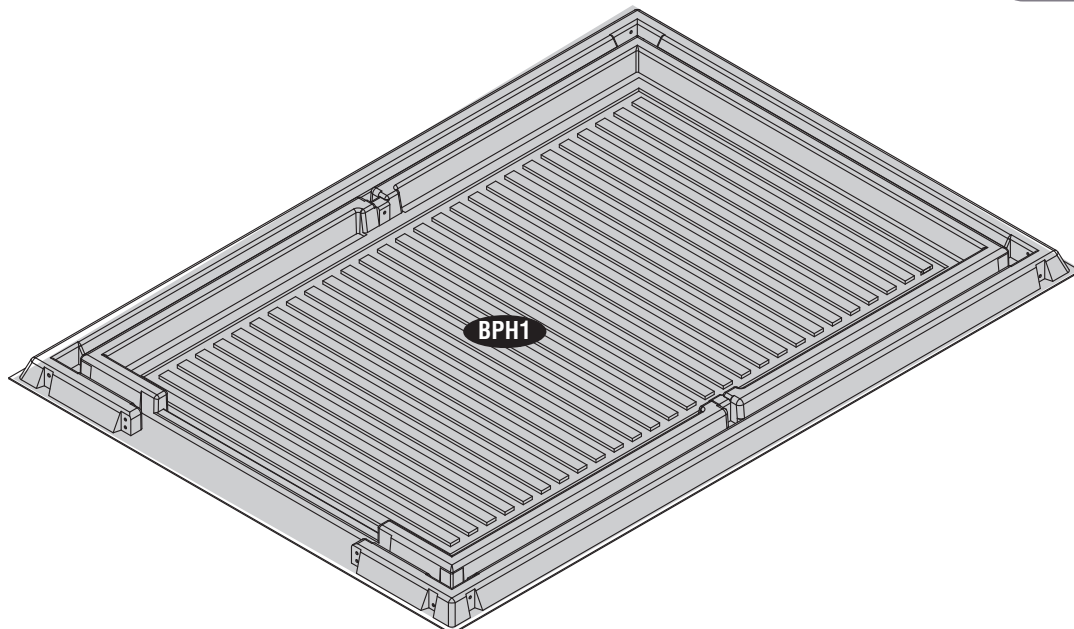
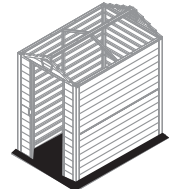

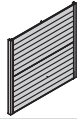

BCRR (x1)



S5 (x1)

S6 (x1)

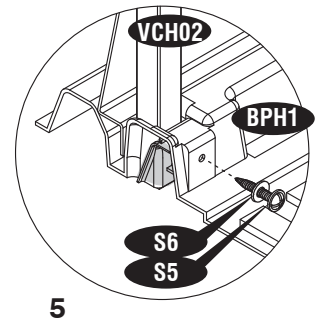
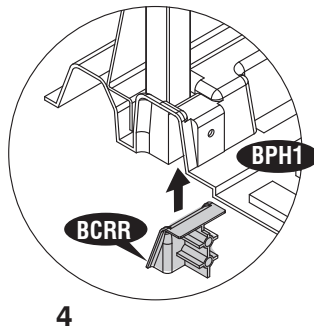
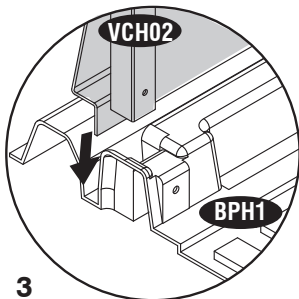
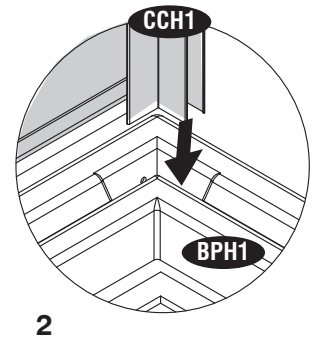
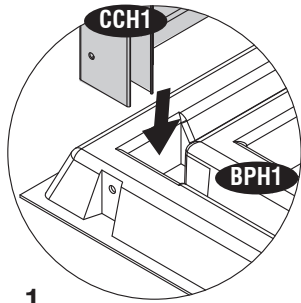
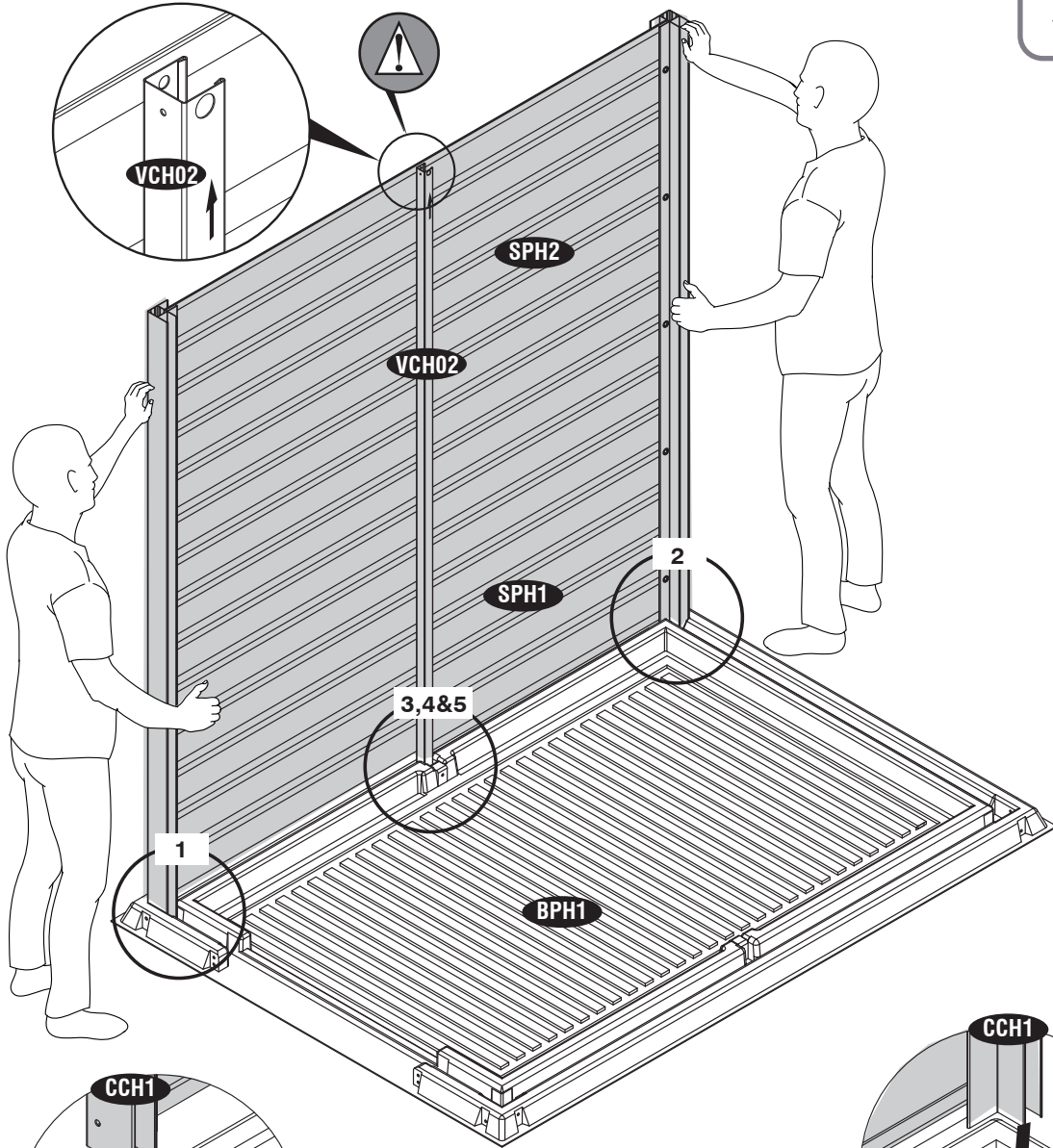
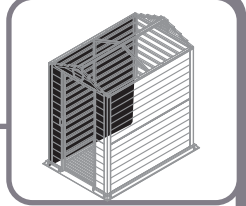



3



BCRR (x4)



S5 (x4)

S6 (x4)

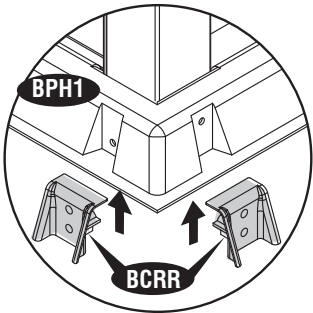
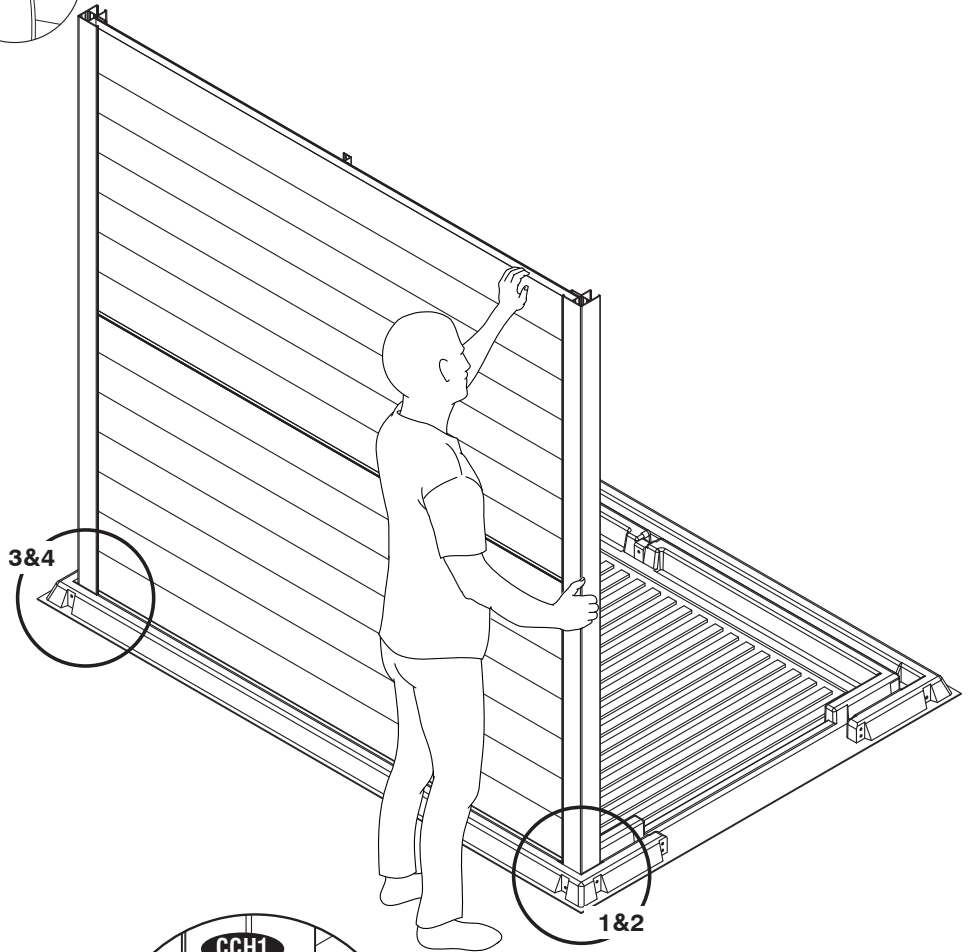
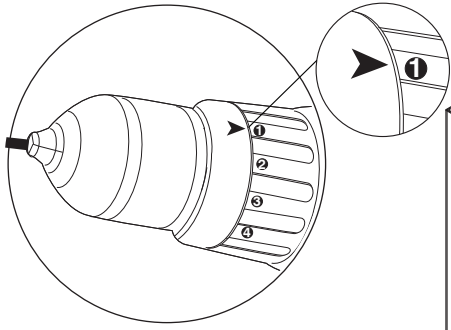
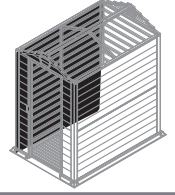

1

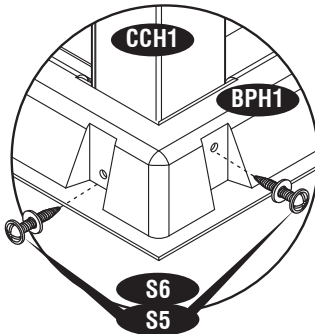

2

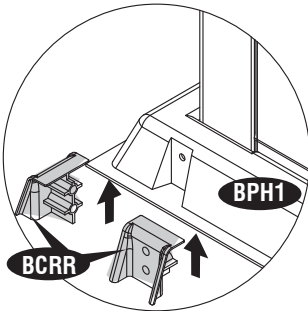

3

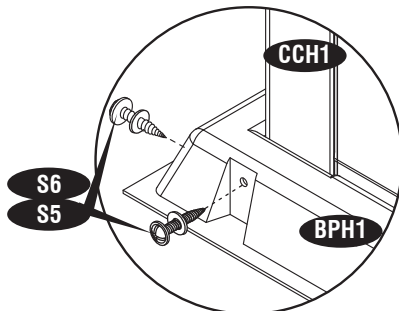

4

4

VRH01 (x1)

S1 (x2)  
S7 (x1)

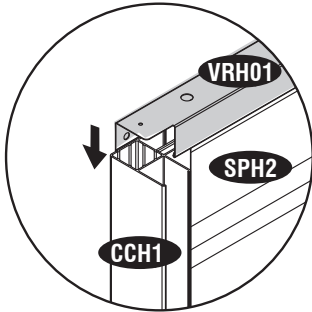
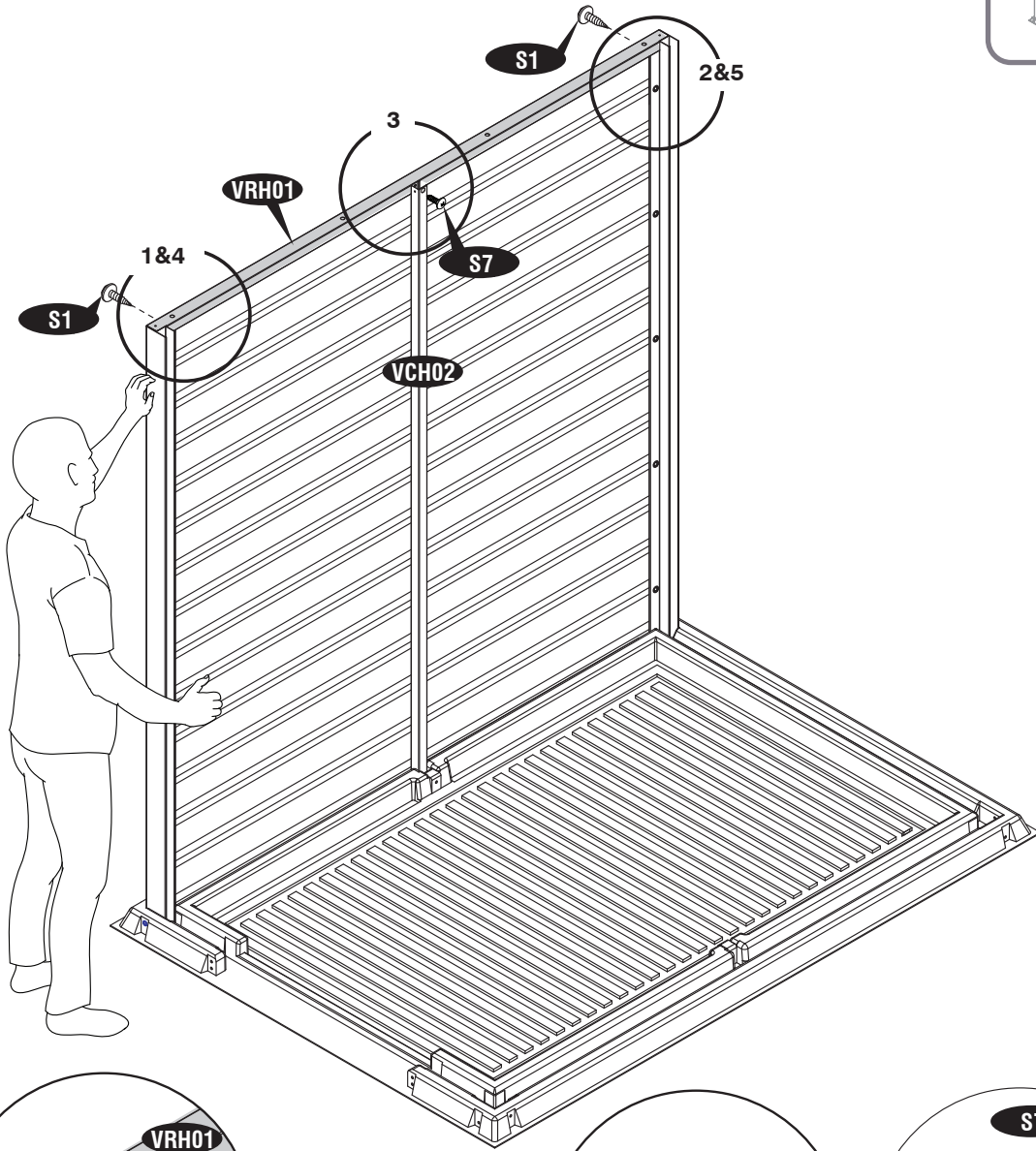
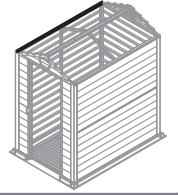

1

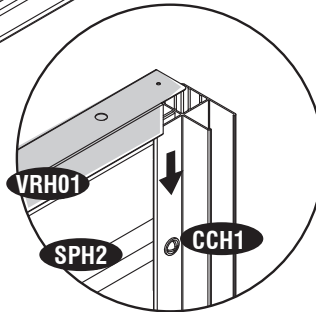

2

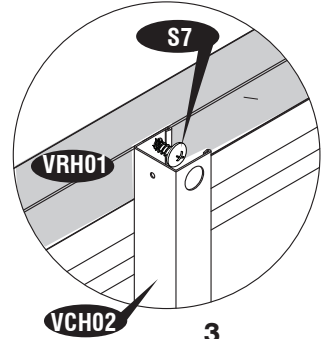

3

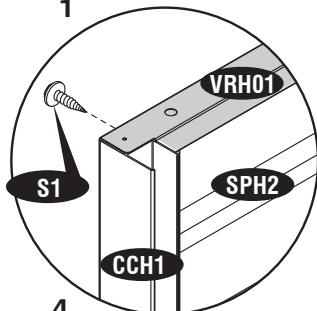

4

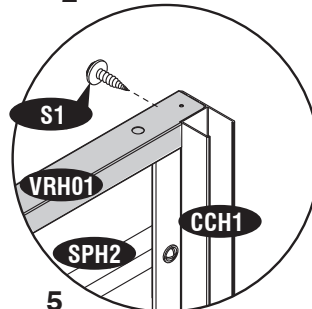

5

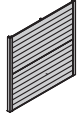

BCRR (x5)



S5 (x5)

S6 (x5)

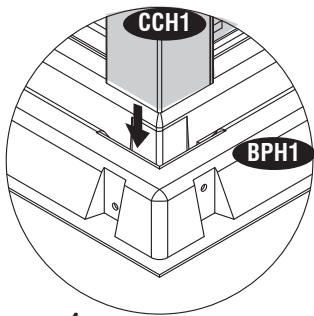
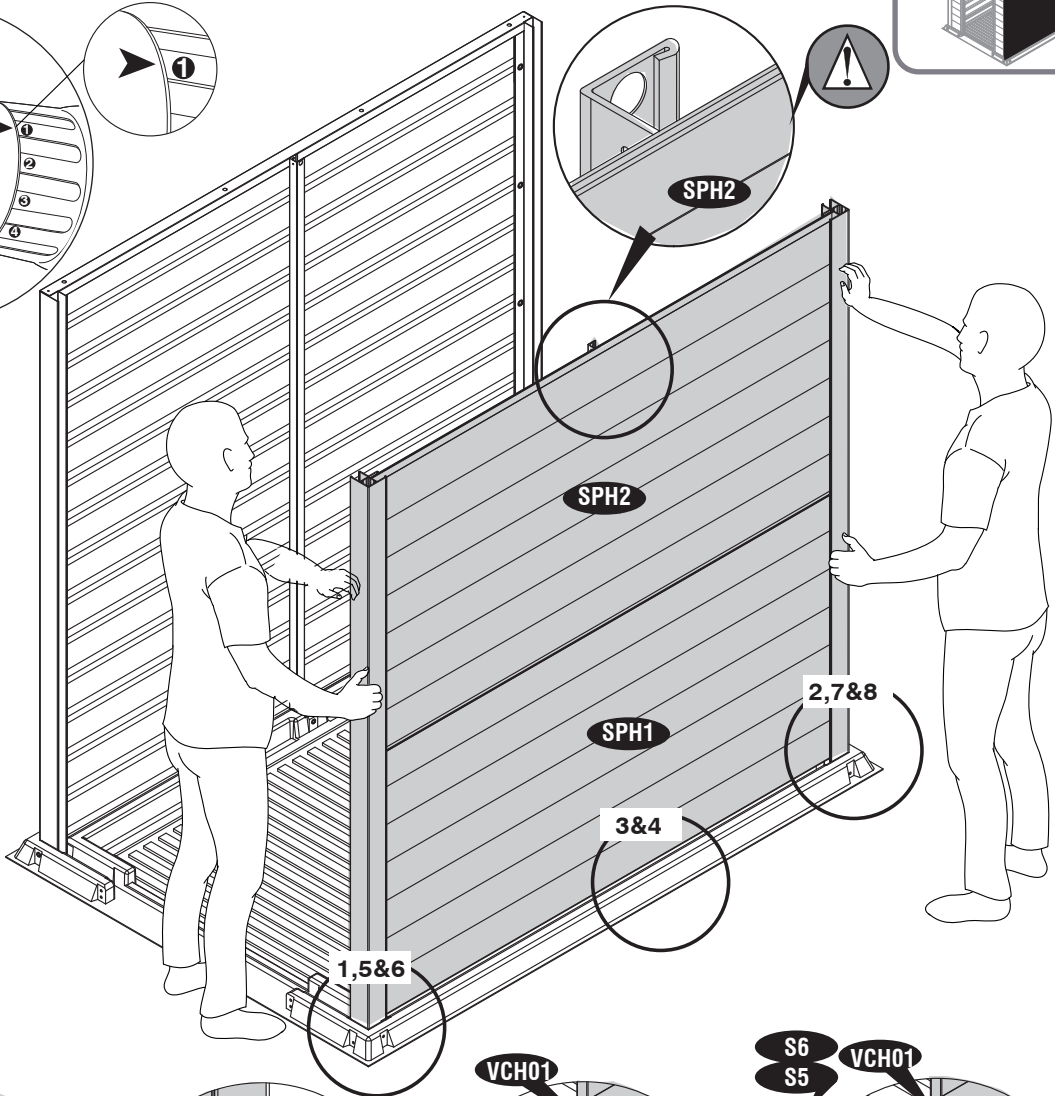
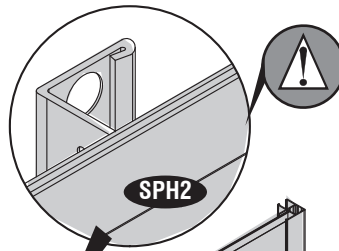
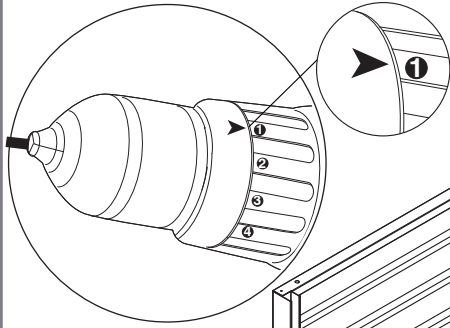
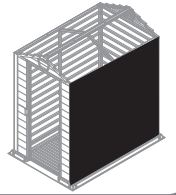

1

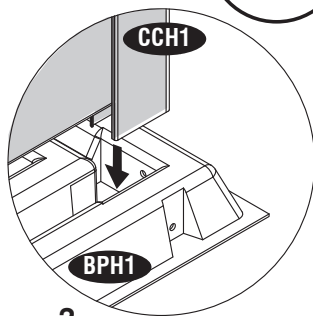

2

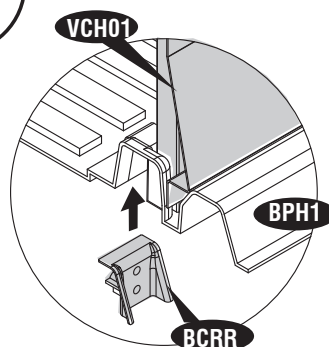

3

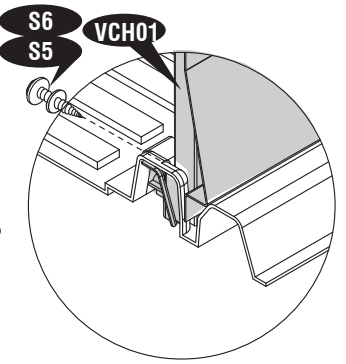

4

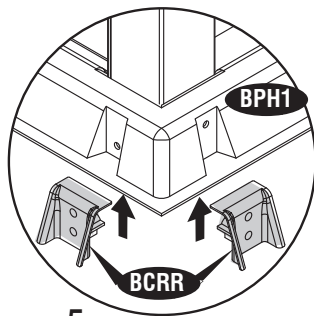

5

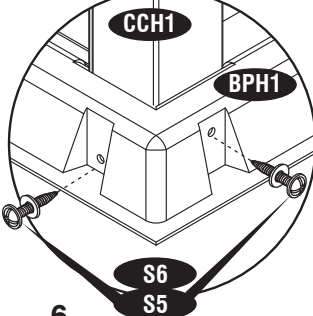

6

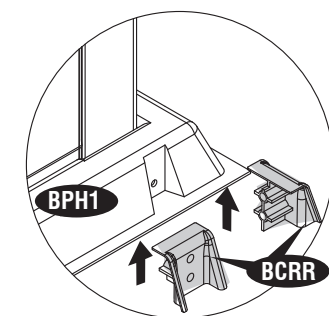

7

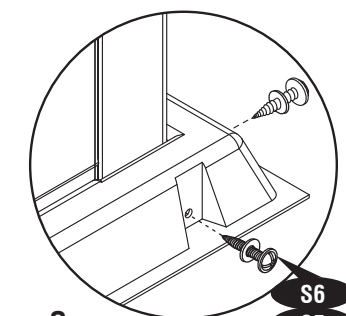

8

6

VRH01 (x1)

S1 (x2)  
S7 (x1)

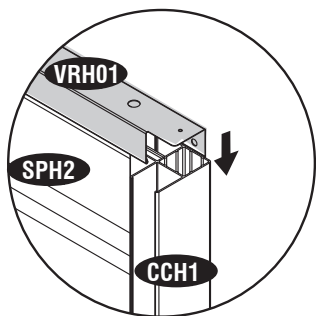
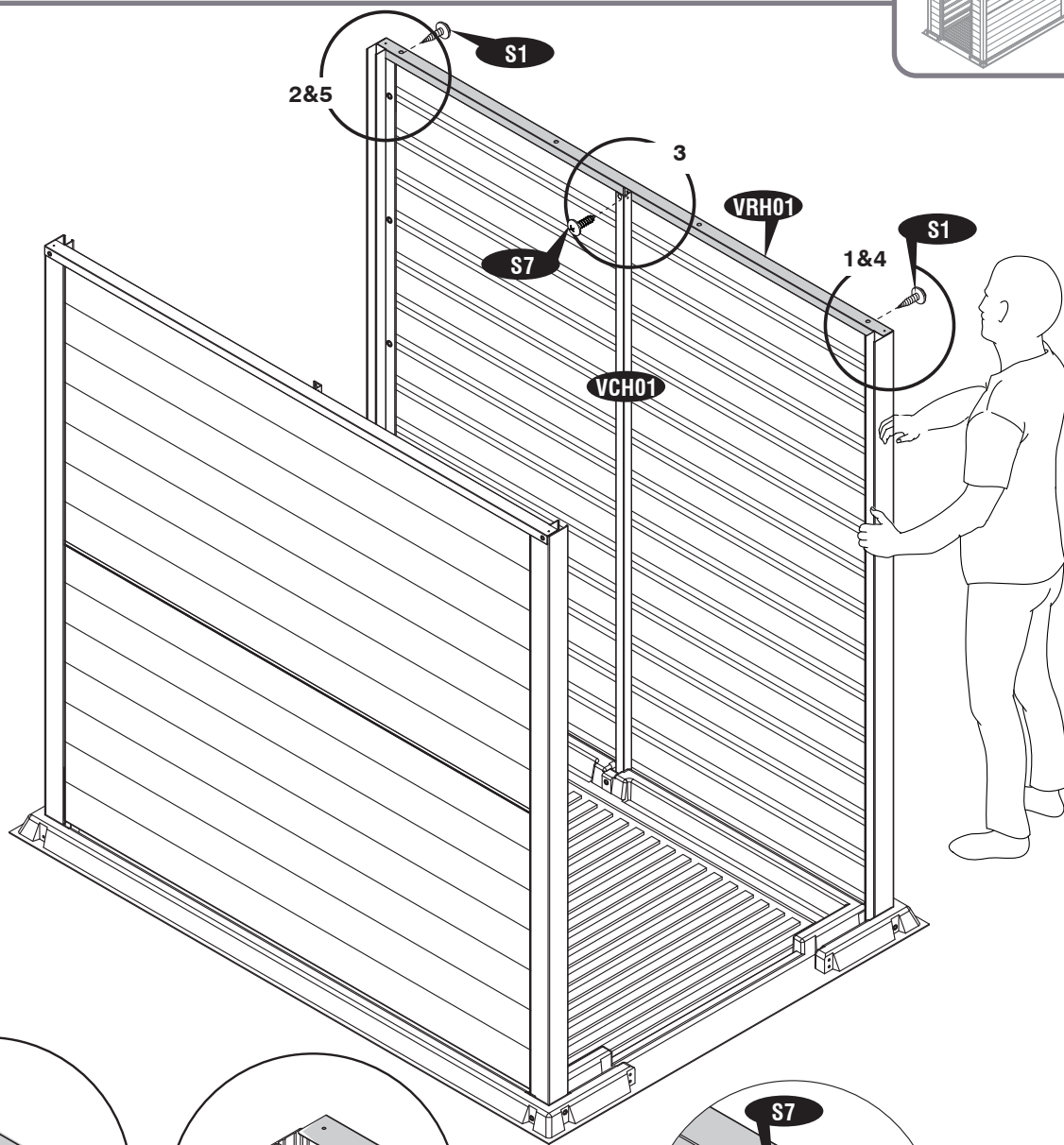
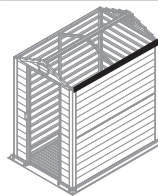

1

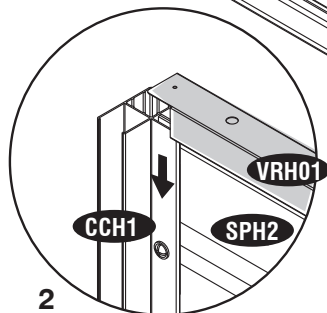

2

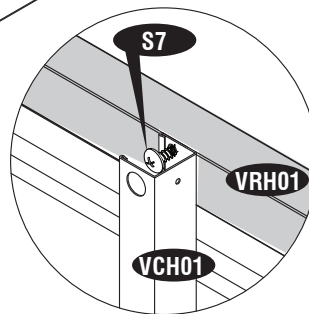

3

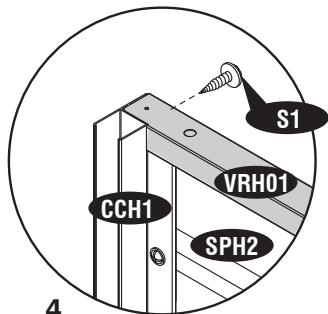

4

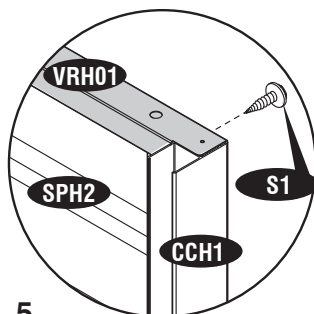

5

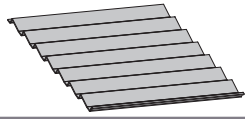

SPH3 (x1)



S1 (x4)

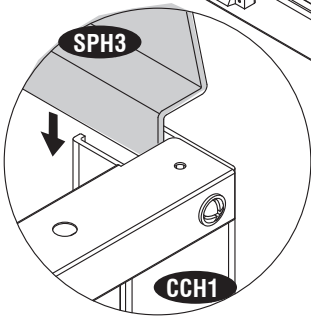
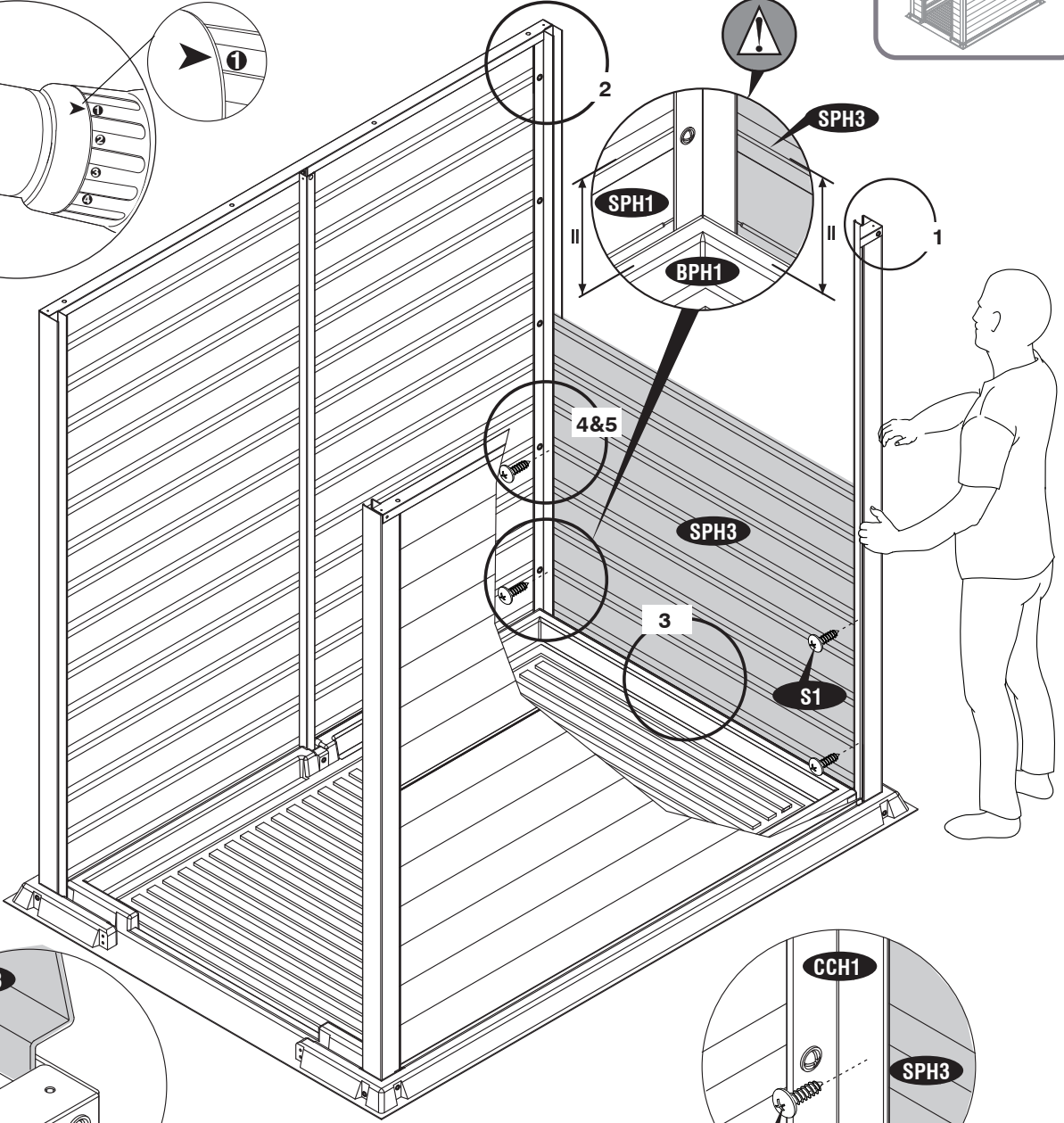
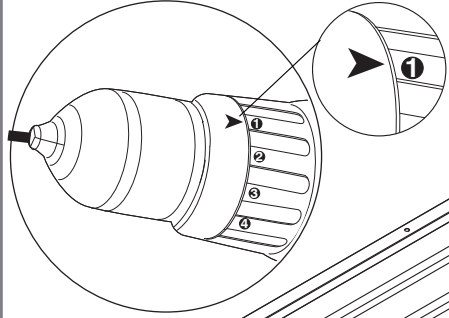
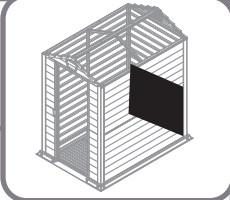

1

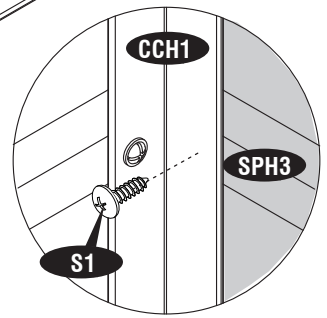

4

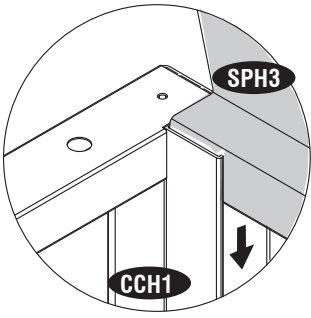

2

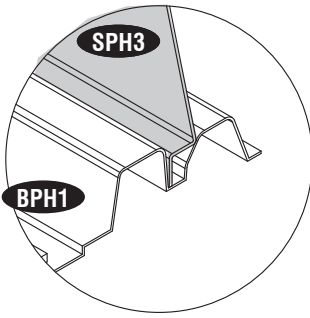

3

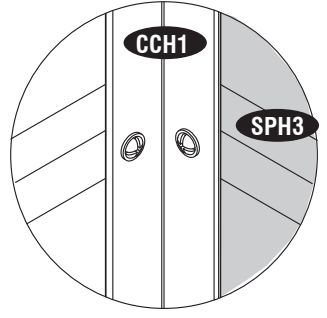

5

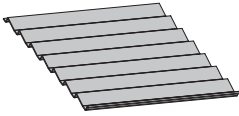

SPH4 (x1)



S1 (x6)

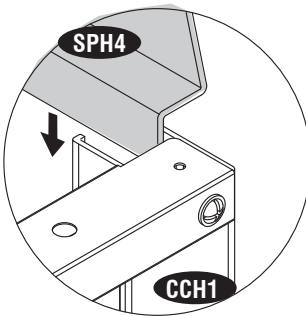
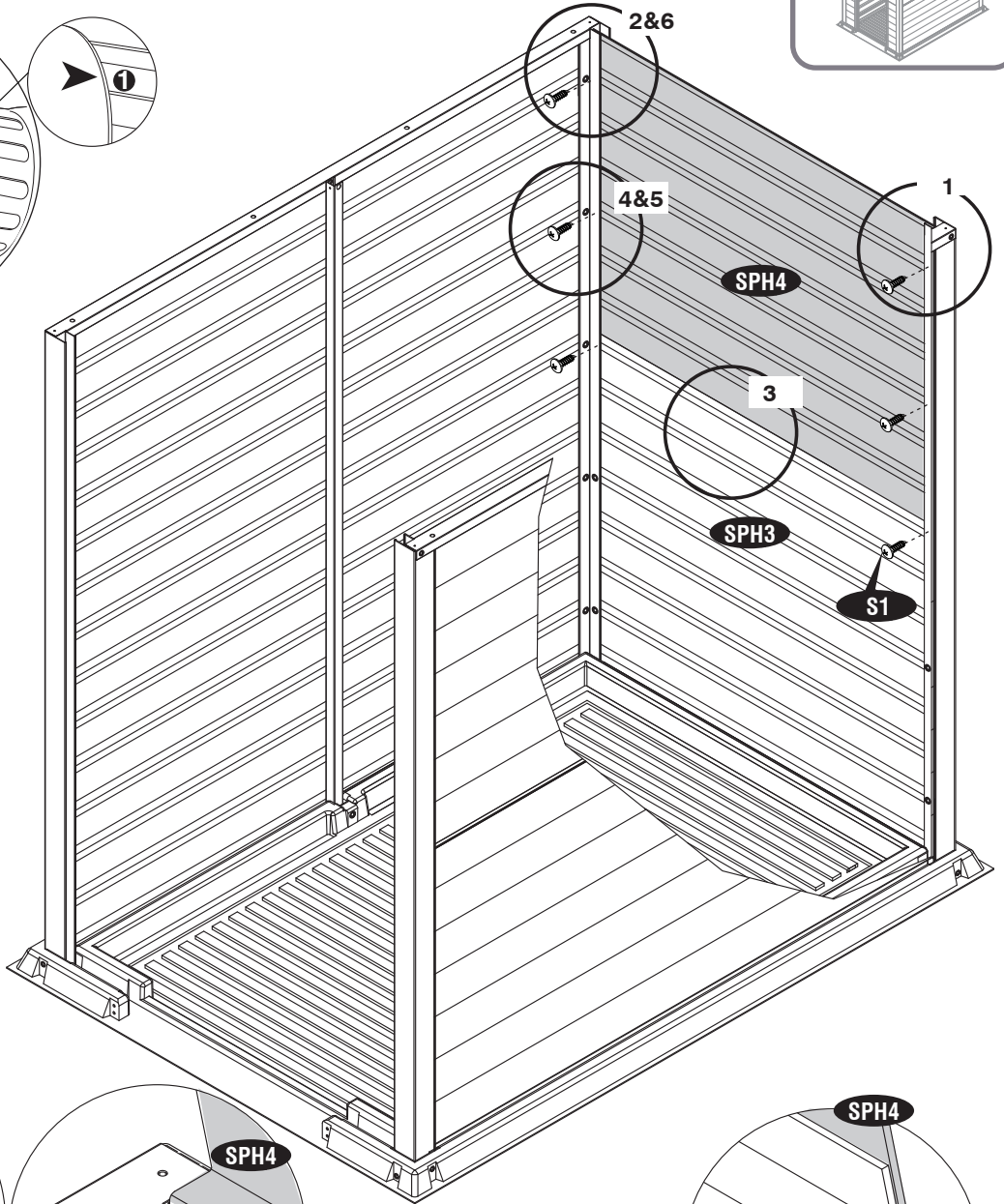
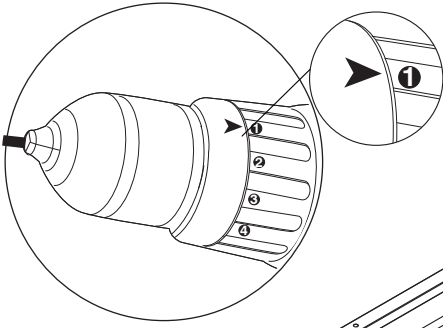
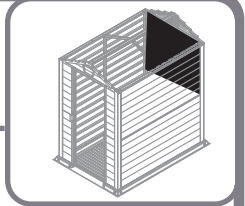

1

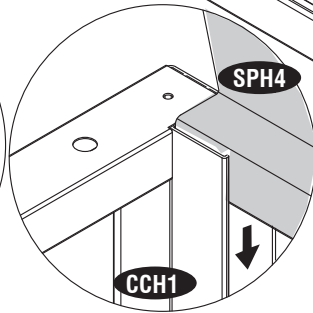

2

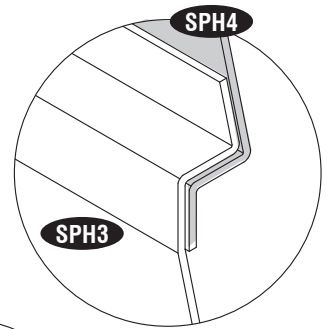

3

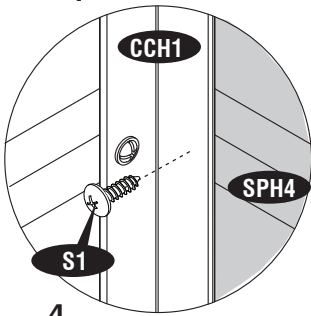

4

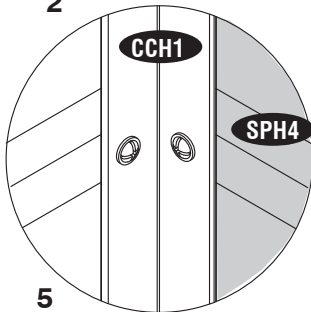

5

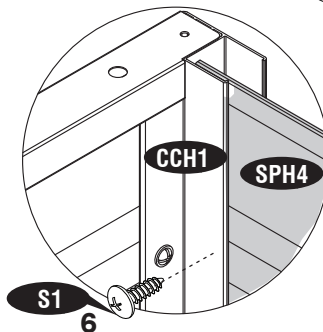

6

9

VRH02 (x1)

S1 (x2)  
S7 (x2)

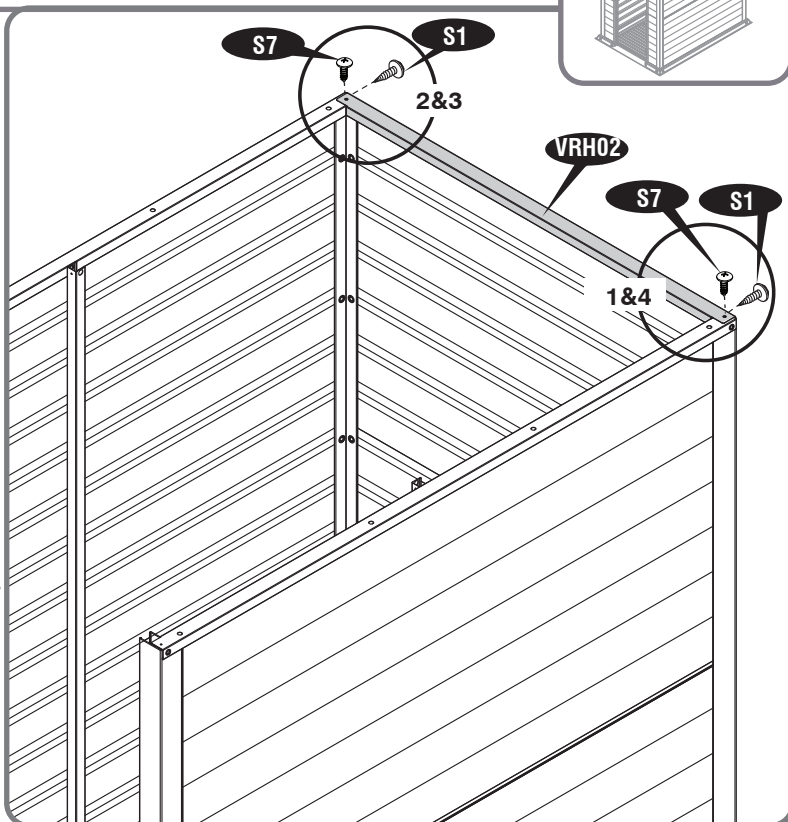
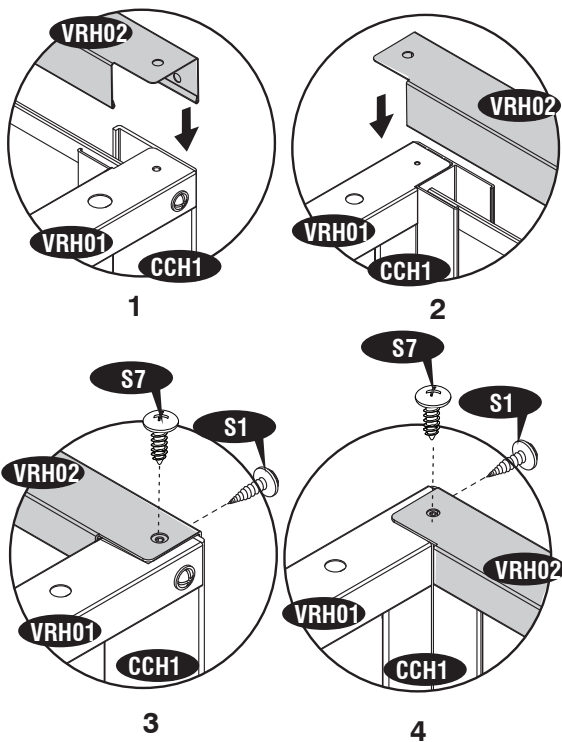
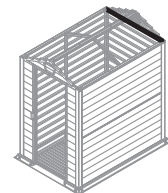

10

SPH5 (x1)

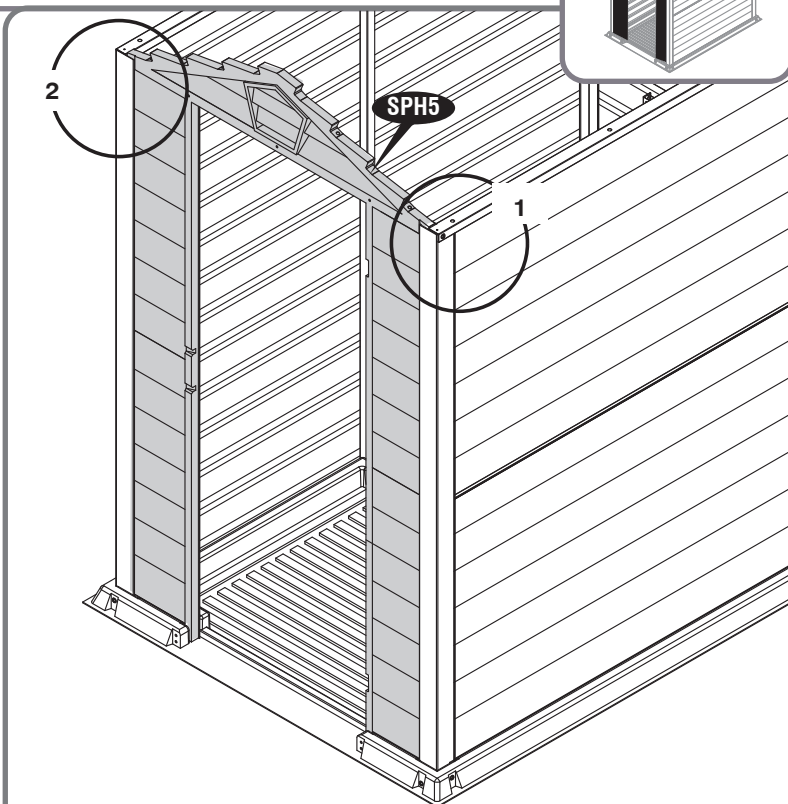
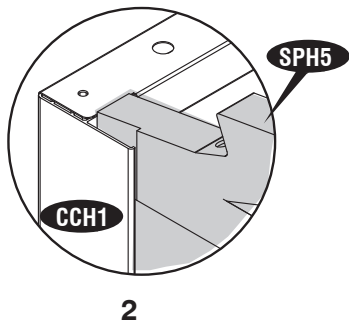
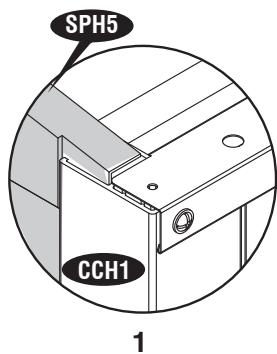
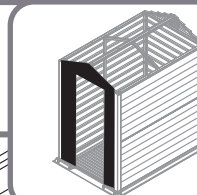

11

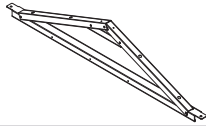

S1 (x2)  
S7 (x2)

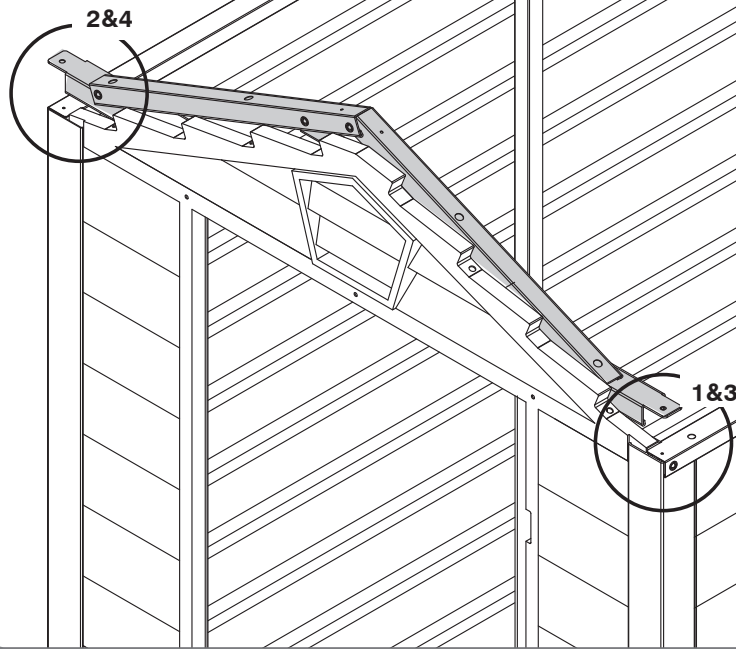
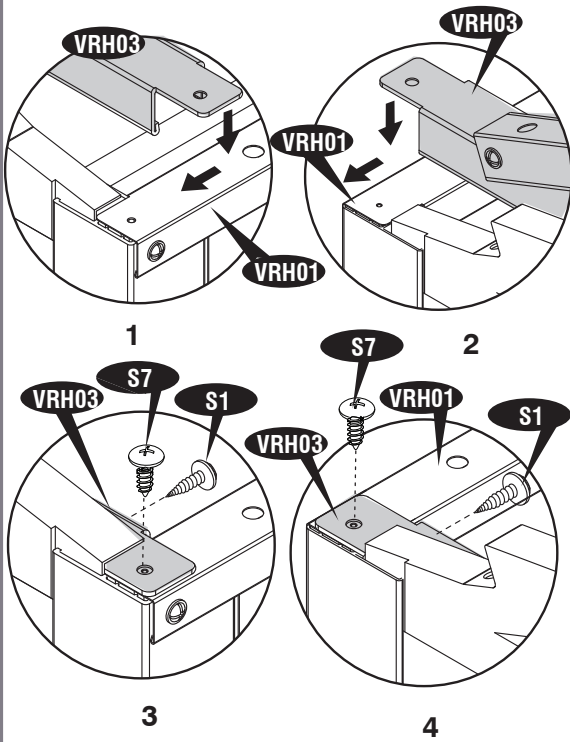
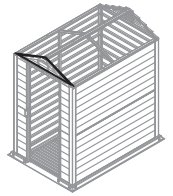

12

VDTH (x1)

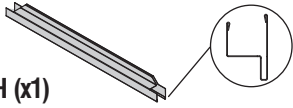

S1 (x1)  
SGC1 (x1)

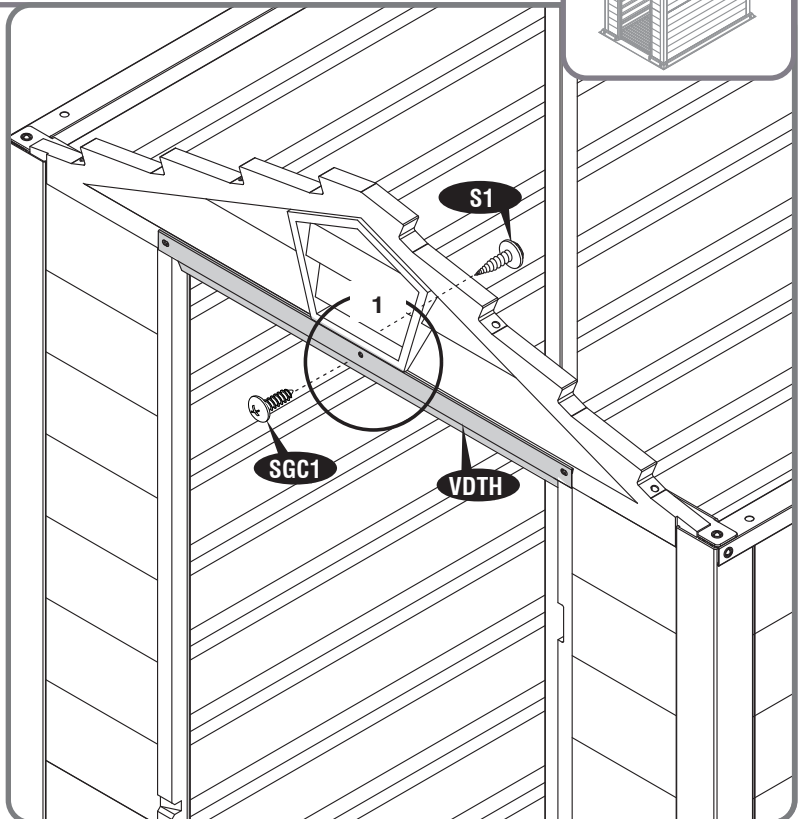
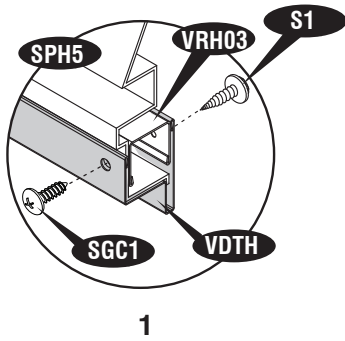
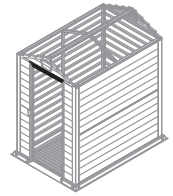



13

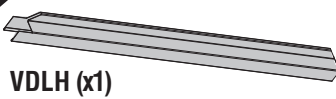

VDLH (x1)



SGC1 (x1)  
S1 (x1)



S5 (x2)  
S6 (x2)

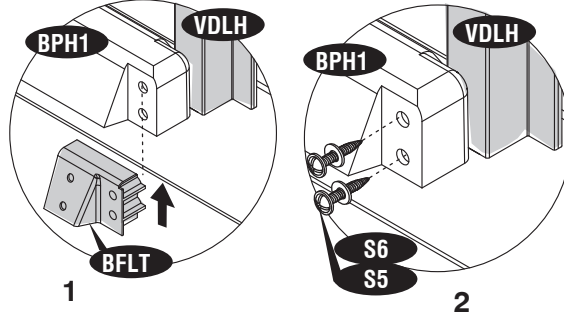
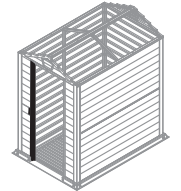

1

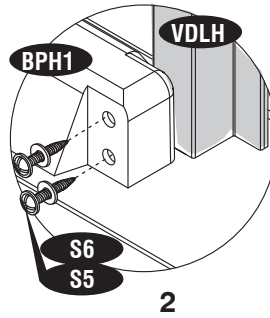

2

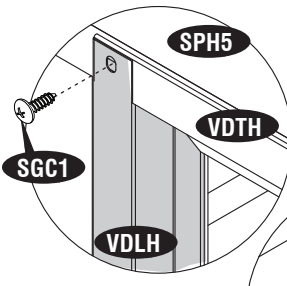

3

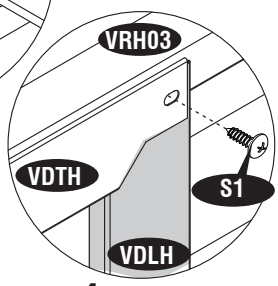

4

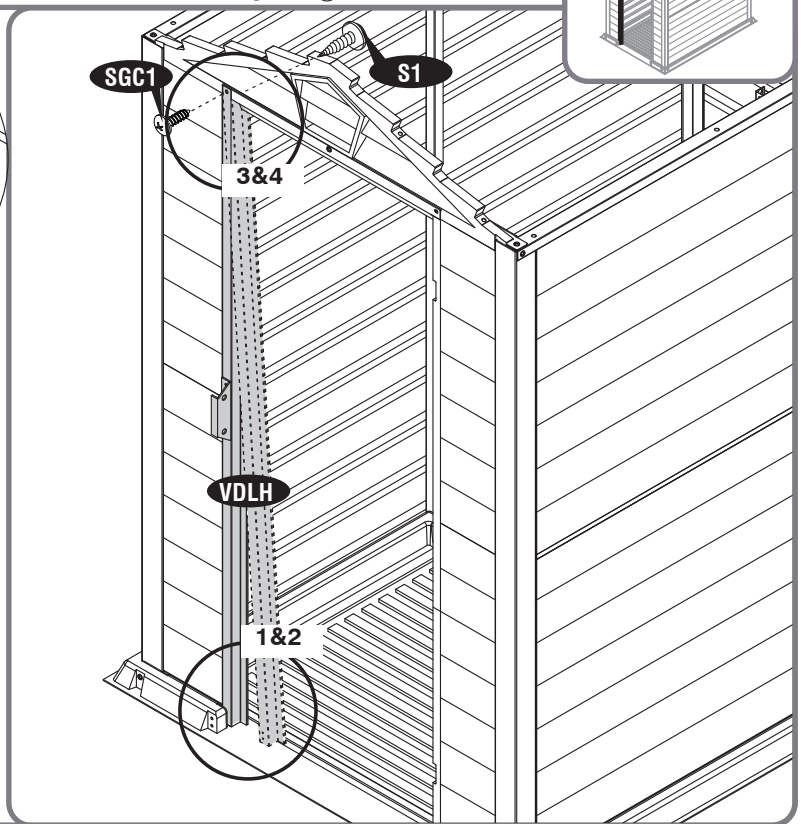

14

VDRH (x1)

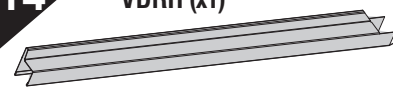

SGC1 (x1)  
S1 (x1)



S5 (x2)  
S6 (x2)

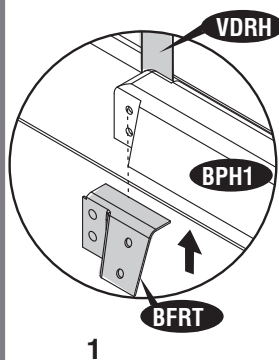
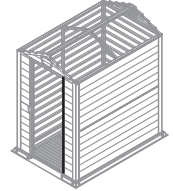

1

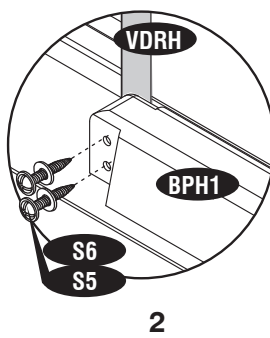

2

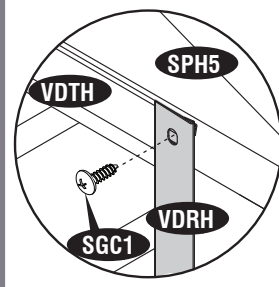

3

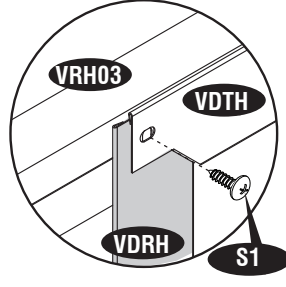

4

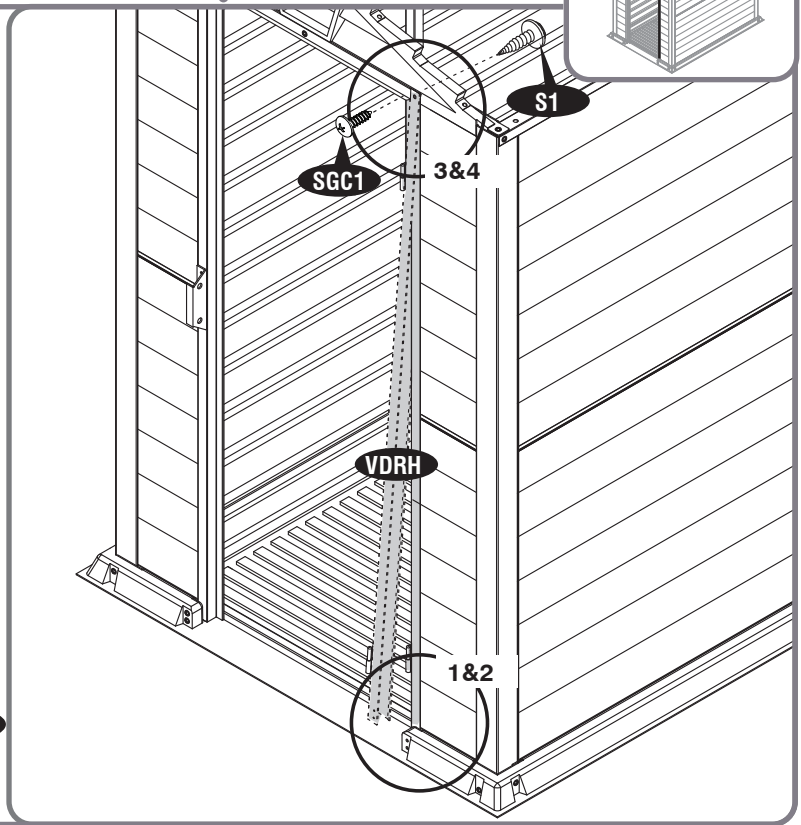

15

S1 (x10)

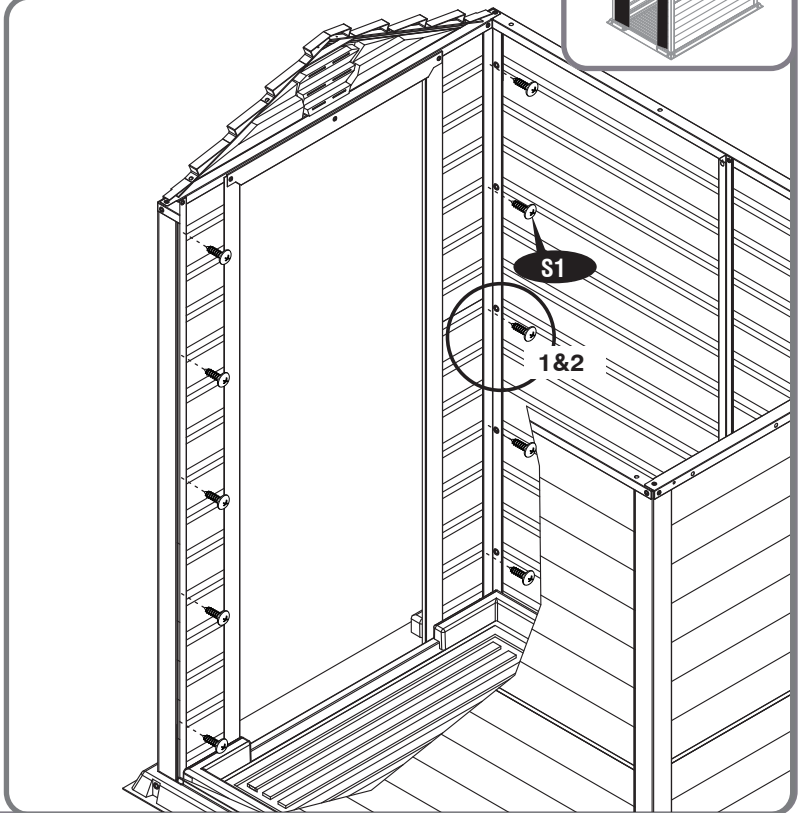
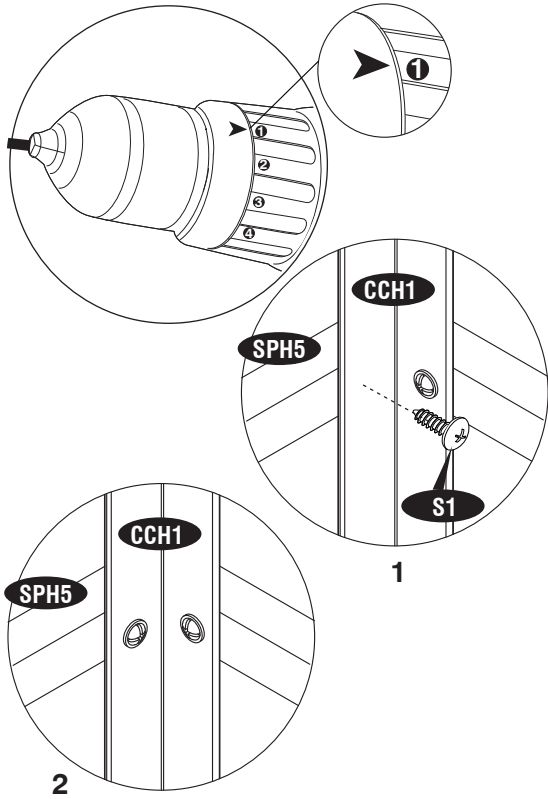
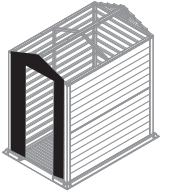

16

S7 (x2)

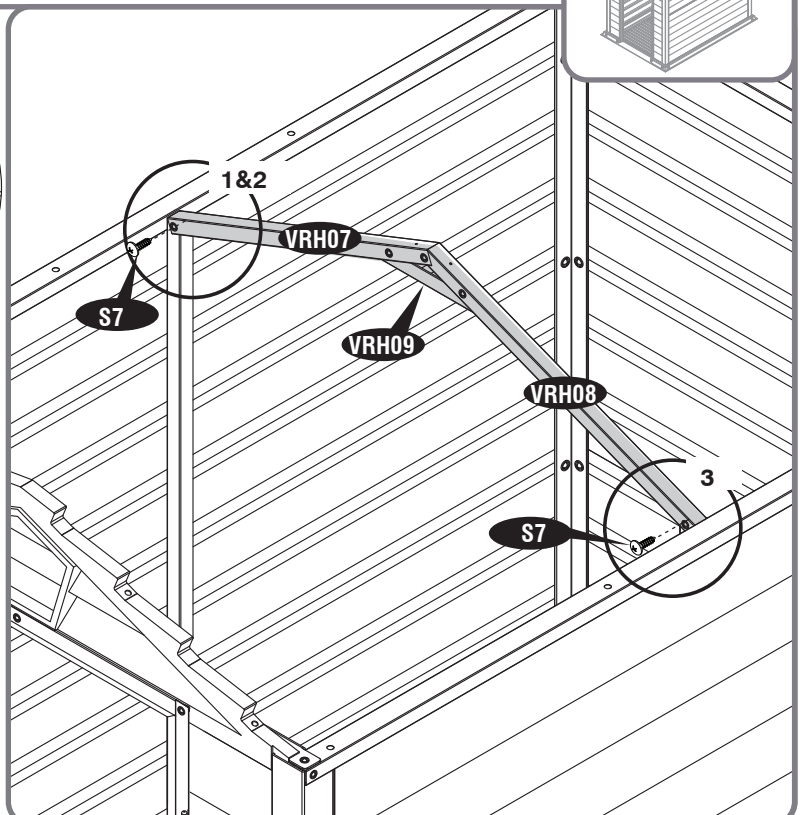
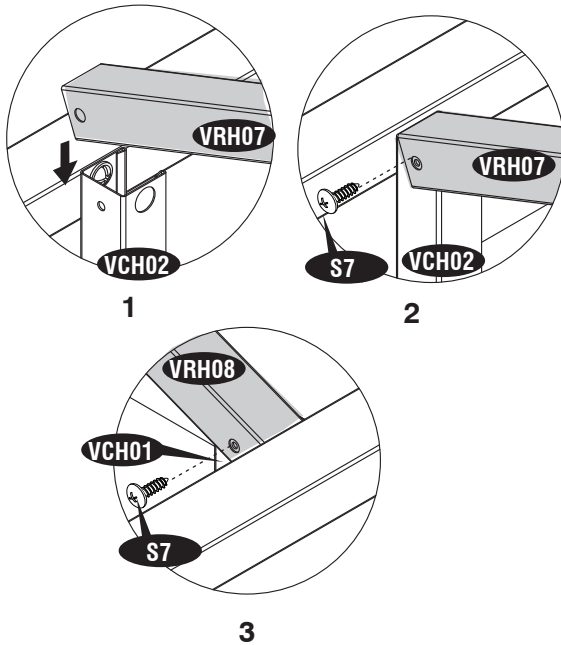
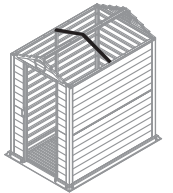

17

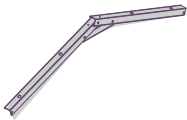

S7 (x2)

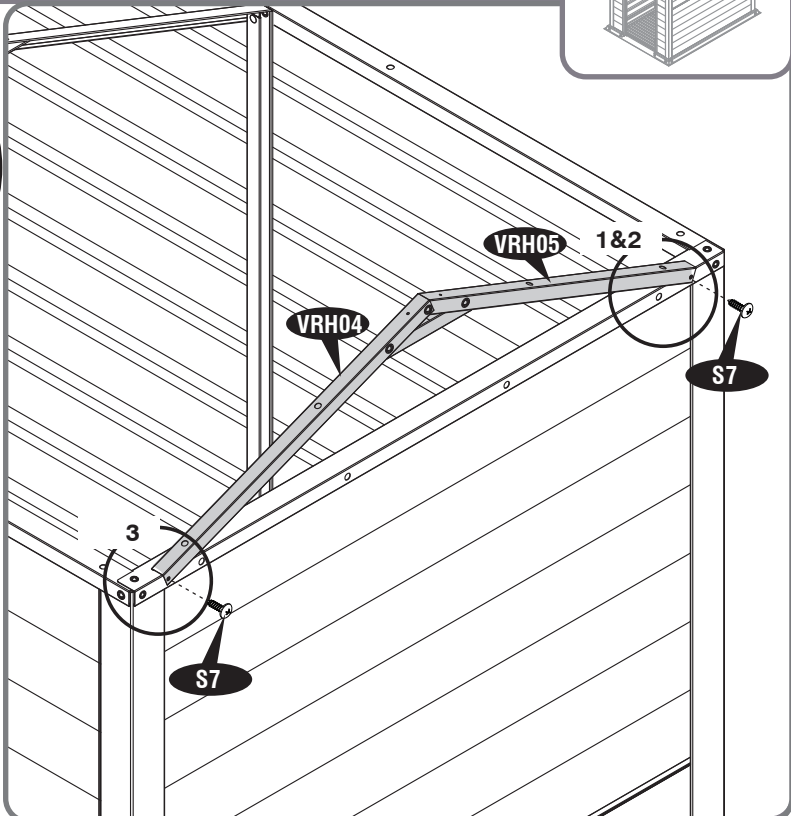
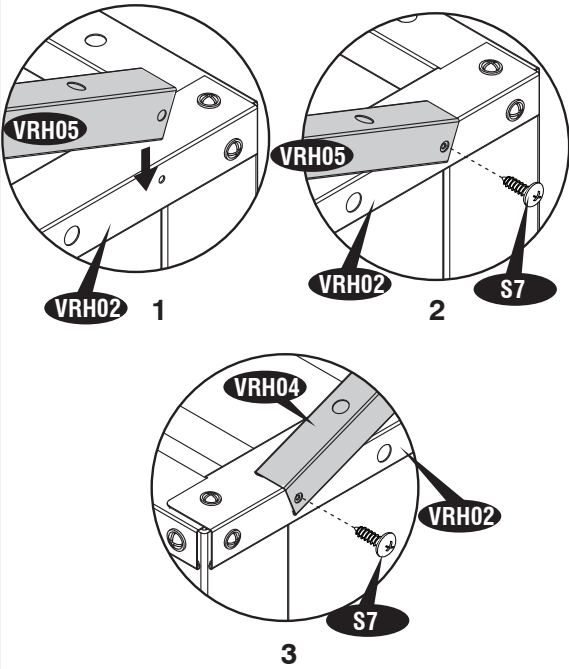
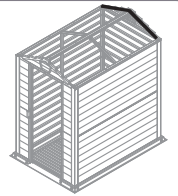

18

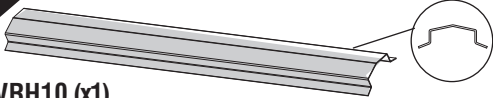

VRH10 (x1)

S7 (x6)

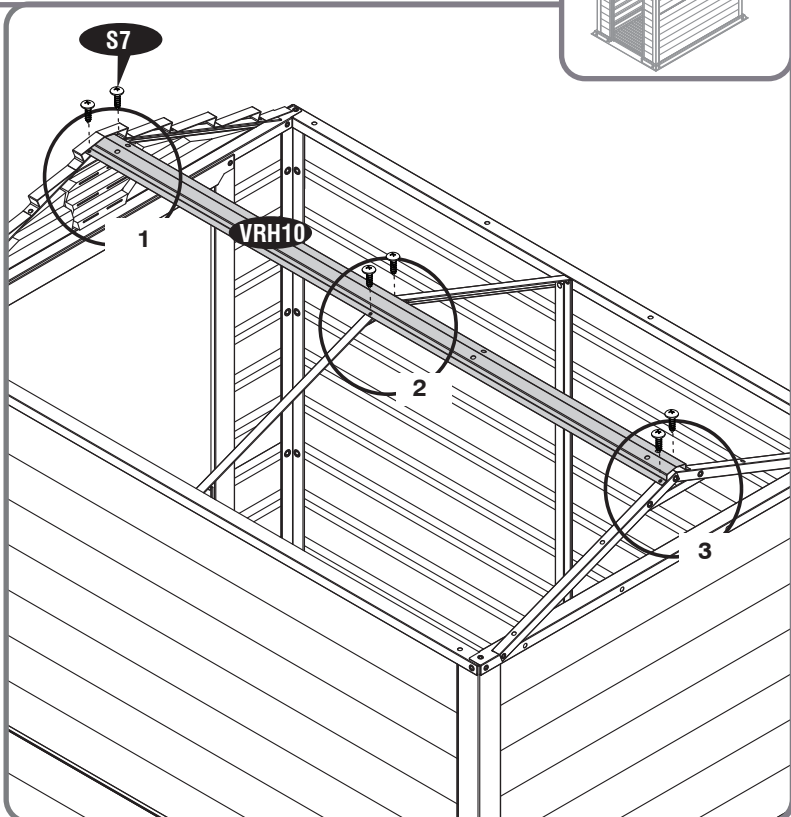
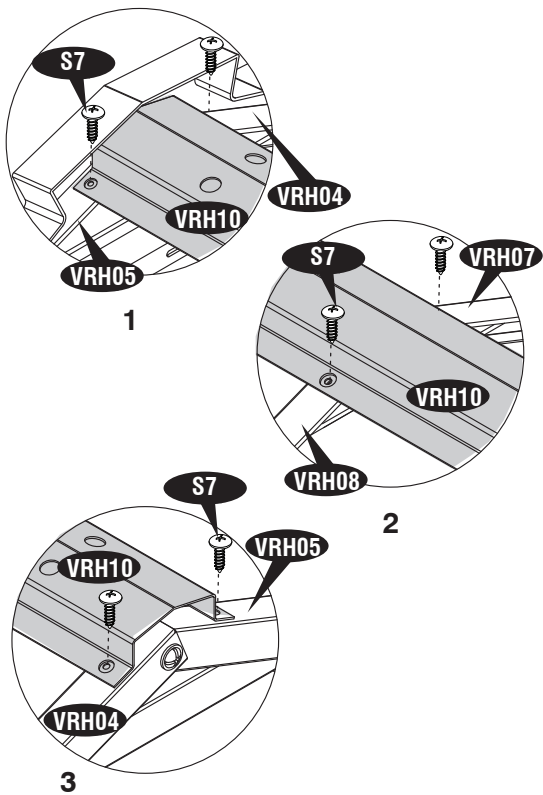
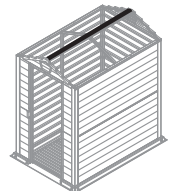

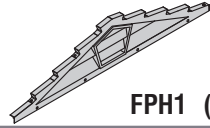

FPH1 (x1)



BP (x6)

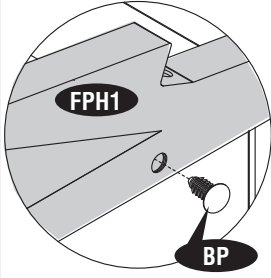
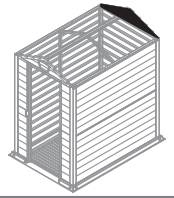

1

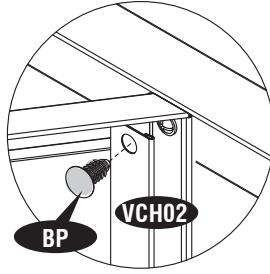

2

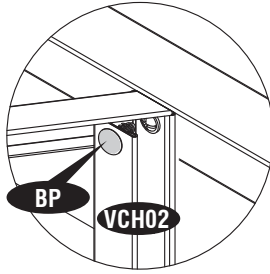

3

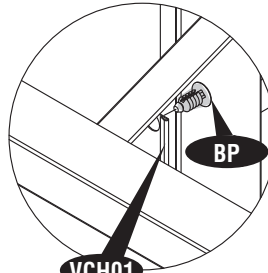

4

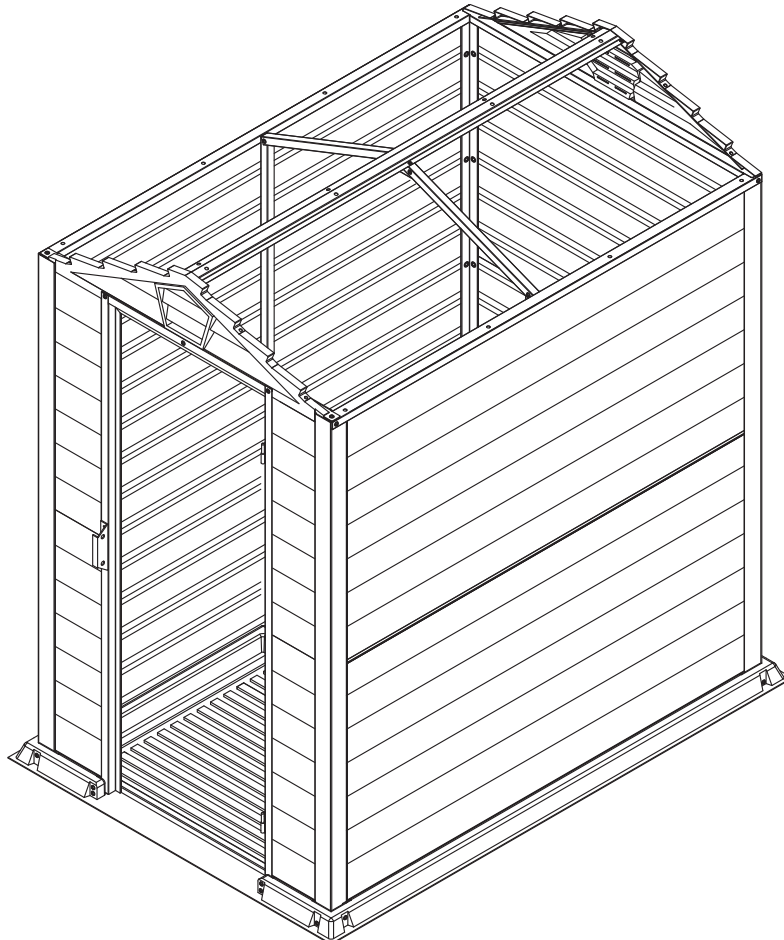
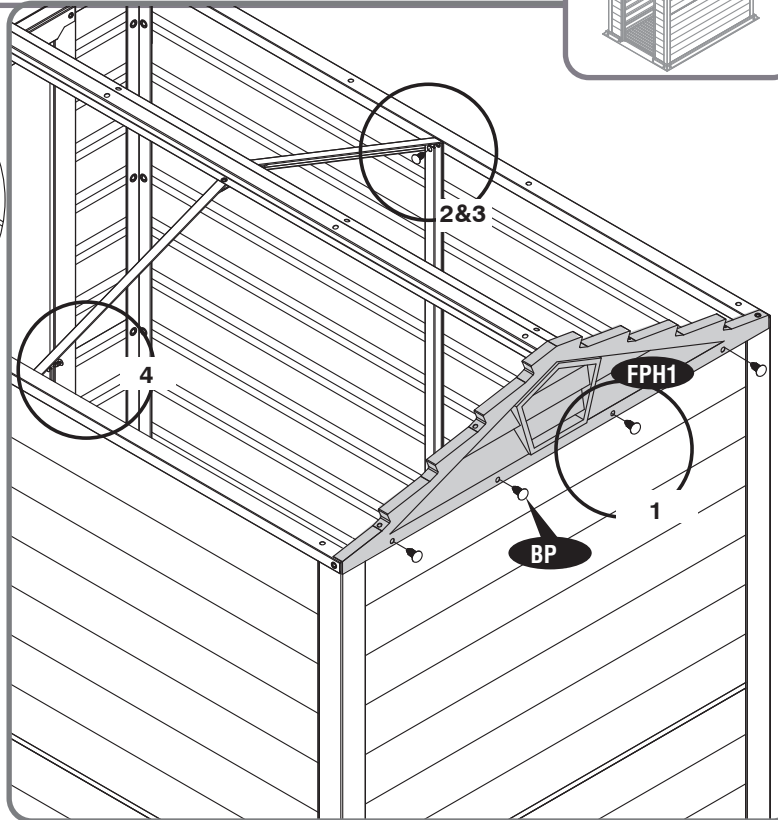



3

- |                        |                   |                        |
|------------------------|-------------------|------------------------|
| EN Roof Panels         | CS Střešní panely | IT Pannelli del tetto  |
| FR Planches de Toiture | SK Strešné panely | PL Panele dachowe      |
| DE Dachplatten         | SL Strešni Paneli | RO Panouri de acoperiș |
| ES Paneles de techo    | HR Krovne ploče   | BG Покривни панели     |
| PT Painéis do Telhado  | HU Tetőpanelek    | TR Çatı Panelleri      |
| NL Dakpanelen          | SV Takpaneler     |                        |

- |                       |                                   |                                   |
|-----------------------|-----------------------------------|-----------------------------------|
| EN Parts needed       | CS Potřebné součásti              | IT Parti occorrenti               |
| FR Pièces nécessaires | SK Potřebné části                 | PL Niezbędne elementy             |
| DE Benötigte Teile    | SL Dele, ki jih boste potrebovali | RO Elementele componente necesare |
| ES Piezas necesitadas | HR Dijelovi potreban              | BG Необходими части               |
| PT Peças Necessárias  | HU Szükséges részek               | TR Gerekli parçalar               |
| NL Onderdelen nodig   | SV Delar som behövs               |                                   |

RPH1	2	PPG	24	TC	4
RPH2	1	PIN	24	FP	4
VRH11	2	S1	4		
VRH12	2	S7	10		



- EN Apply silicone into the holes before inserting the pins (Silicone not included).
- FR Appliquez de la silicone dans les trous avant d'insérer les broches (silikon nicht enthalten).
- DE Anwenden Silikon in die Löcher vor dem Einsetzen der Stifte (Silikon nicht enthalten).
- ES Aplicar silicona en los agujeros antes de insertar los pasadores (Silicona no incluido).
- PT Aplique silicone nos orifícios antes de inserir os pinos (Silicone não incluído).
- NL Breng siliconen aan in de gaten voordat u de pinnen inbrengt (siliconen niet inbegrepen).
- CS Použijte silikon do otvorů před vložením kolíků (silikon není součástí dodávky).
- SK Silikón naneste do otvorov pred vložením kolíkov (silikón nie je súčasťou dodávky).
- SL Vstavite silikon v luknje, preden vstavite zatič (silikon ni priložen).
- HR Nanesite silikon u rupe prije umetanja igle (Silikonski dio nije uključen).
- HU A tűk behelyezése előtt szilikont kell behelyezni a lyukba (a szilikon nem tartozék).
- SV Applicera silikon i hålen innan du sätter in stiften (Silikon ingår inte).
- IT Applicare il silicone nei fori prima di inserire i perni (non in silicone).
- PL Stosuje się silikon w otwory przed włożeniem szpilki (nie zawiera silikonu).
- RO Aplicați siliconul în orificii înainte de a introduce știfturile (siliconul nu este inclus).
- BG Нанесете силикон в дупките преди да поставите щифтовете (силикон не са включени).
- TR Pimleri yerleştirmeden önce deliğe silikon uygulayın (Silikon dahil değildir).

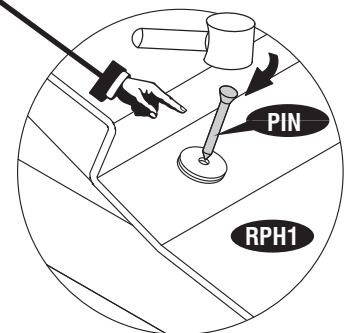
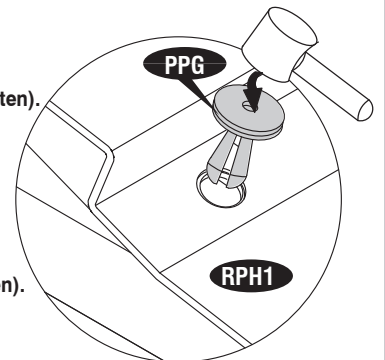

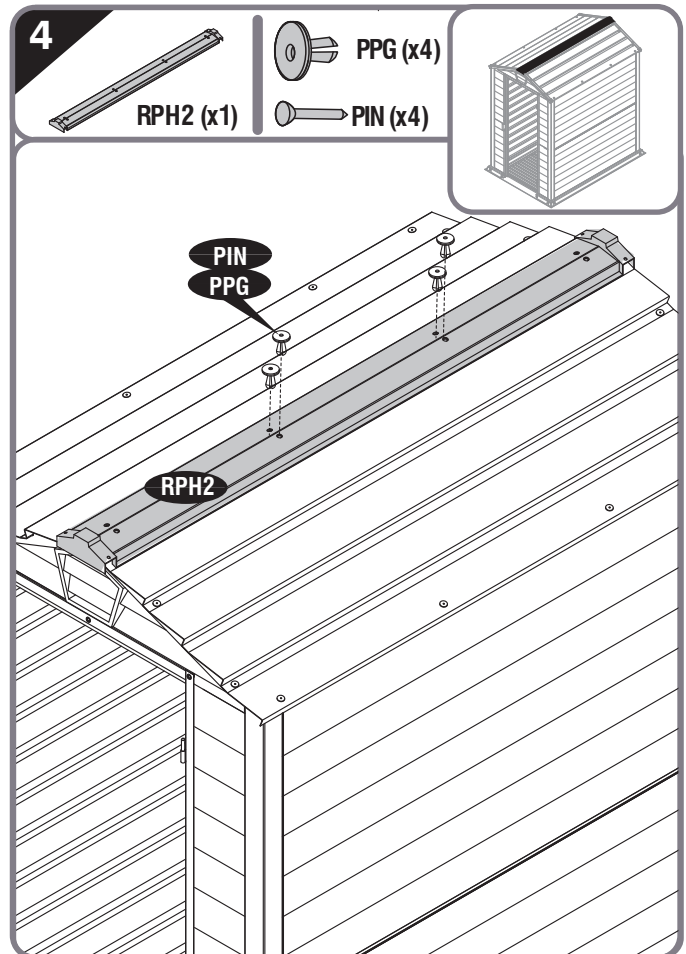
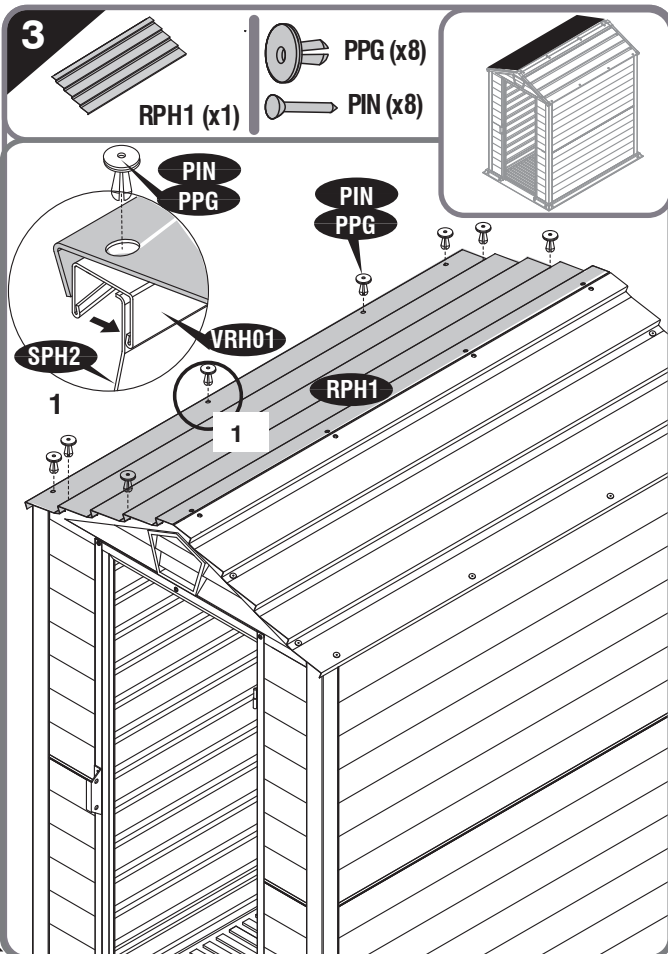
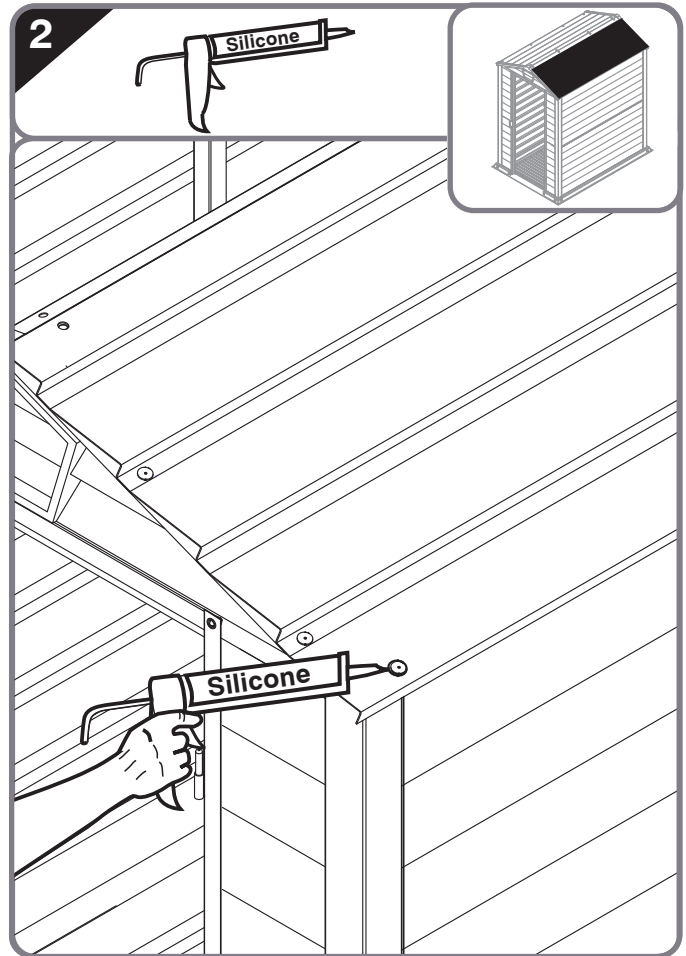
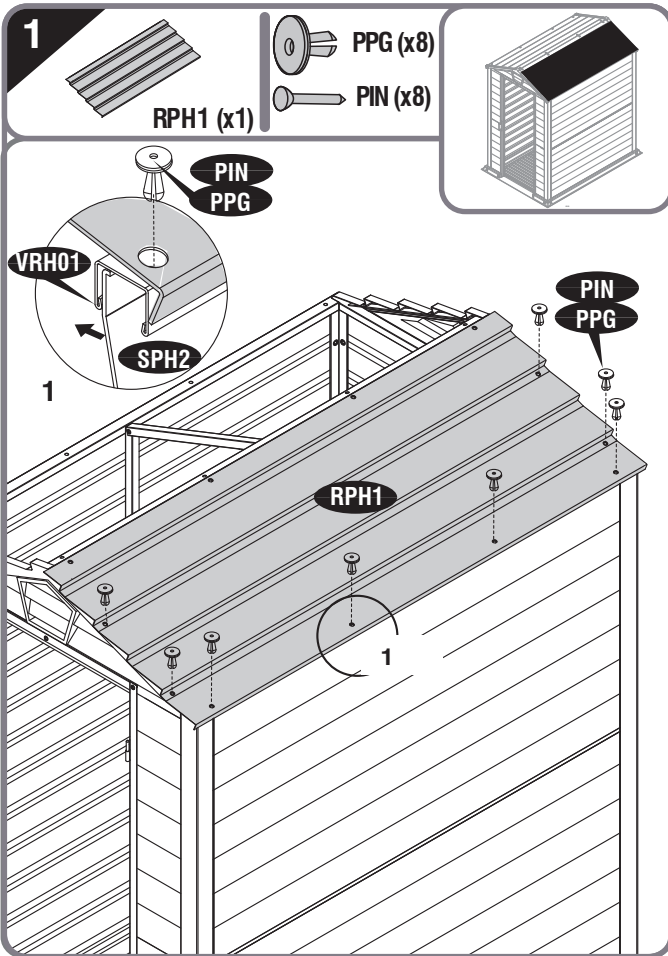

**5**

VRH11 (x2)  
VRH12 (x2)

S7 (x2)

1

**x2**

2

**6**

FP (x2)

PPG (x2)

PIN (x2)

VRH11

VRH12

RPH2

FP

PIN

PPG

**7**

FP (x2)

PPG (x2)

PIN (x2)

VRH11

VRH12

RPH2

FP

PIN

PPG

**8**

TC (x2)

S1 (x2)

TC

S1

VRH11

VRH12

9

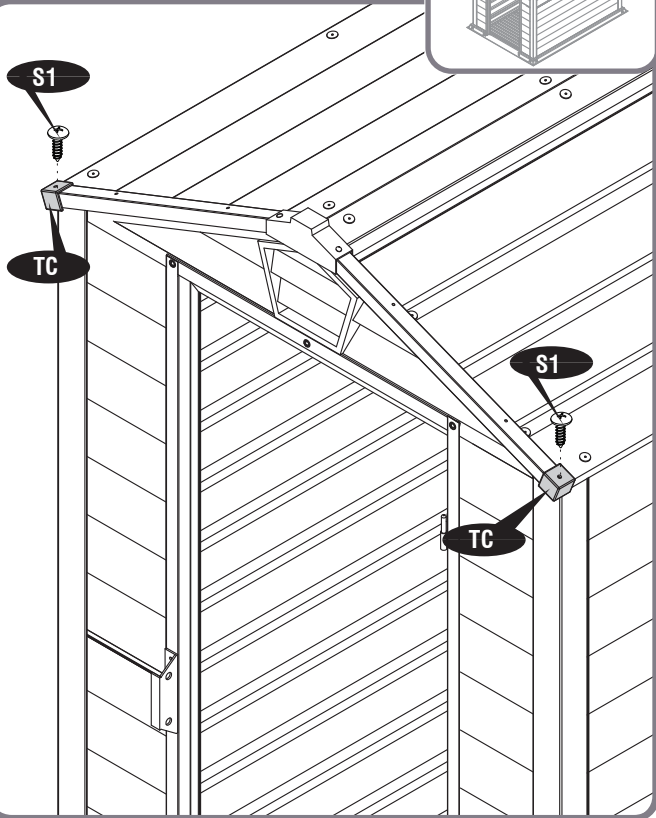
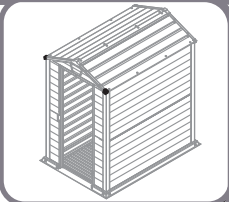
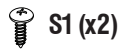

10

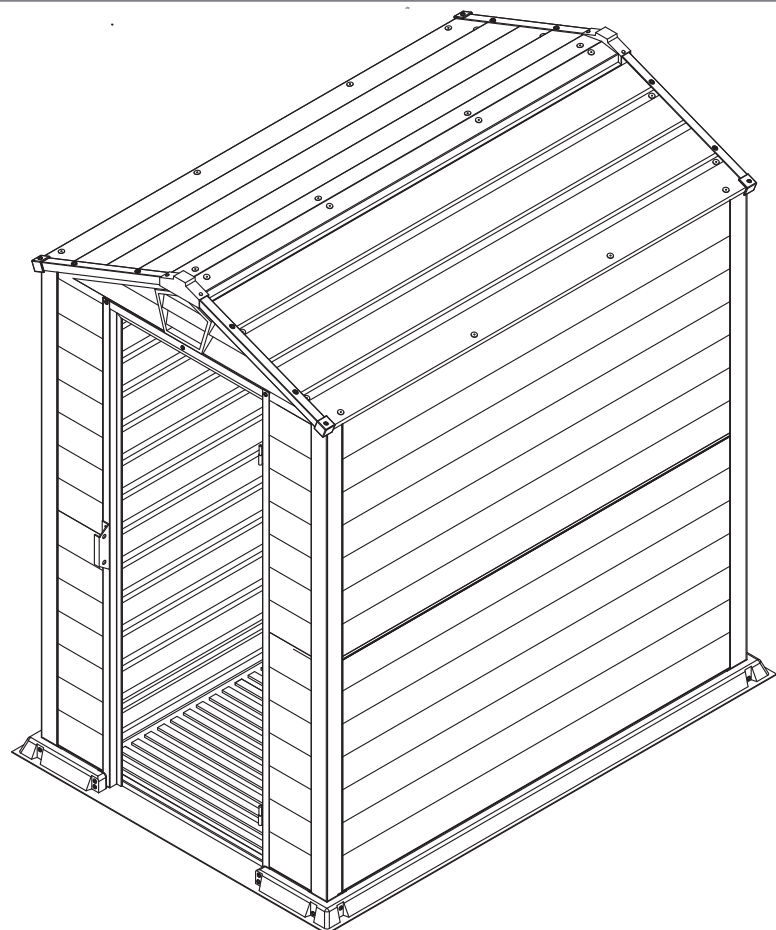
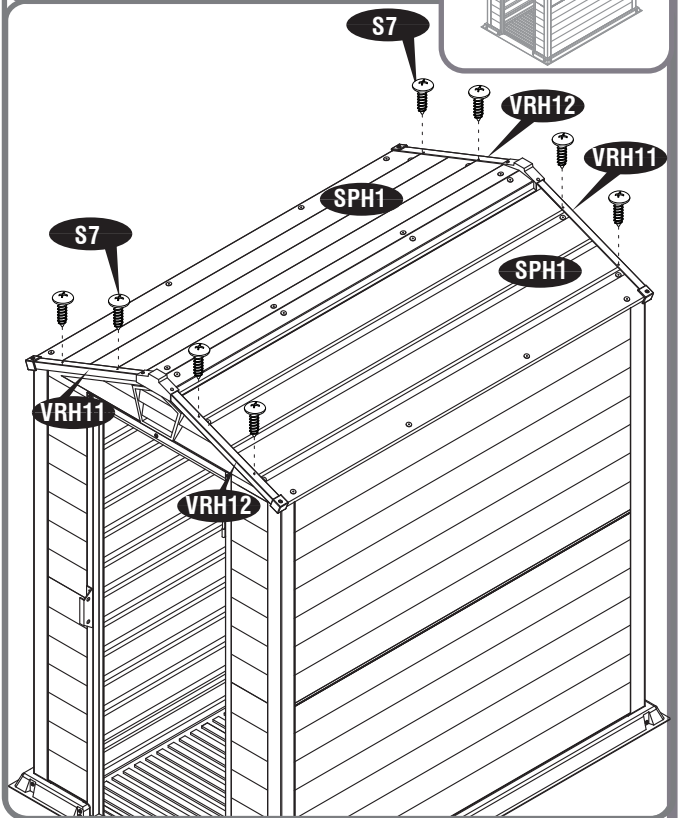
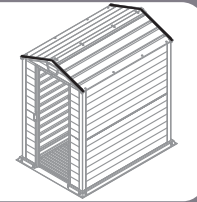





4

EN Door

FR Porte

DE Die Tür

ES La puerta

PT Porta

NL De deur

CS Dveře

SK Dvere

SL Vrata

HR Vrata

HU Ajtó

SV Dörr

IT Porta

PL Drzwi

RO Ușa

BG Врата

TR Kapı

EN Parts needed

FR Pièces nécessaires

DE Benötigte Teile

ES Piezas necesarias

PT Peças Necessárias

NL Onderdelen nodig

CS Potřebné součásti

SK Potrebne časti

SL Dele, ki jih boste potrebovali

HR Dijelovi potreban

HU Szükséges részek

SV Delar som behövs

IT Parti occorrenti

PL Niezbędne elementy

RO Elementele componente necesare

BG Необходими части

TR Gerekli parçalar

DH

1



1

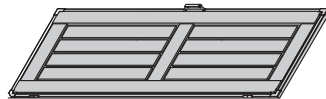

DH (x1)

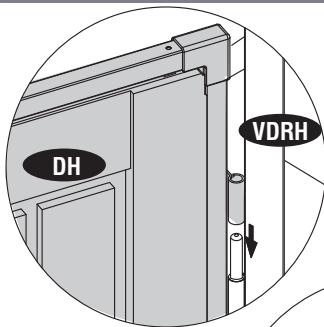
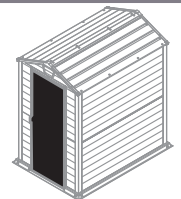

1

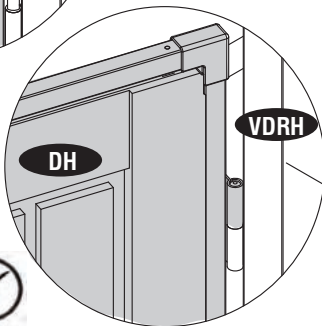

2

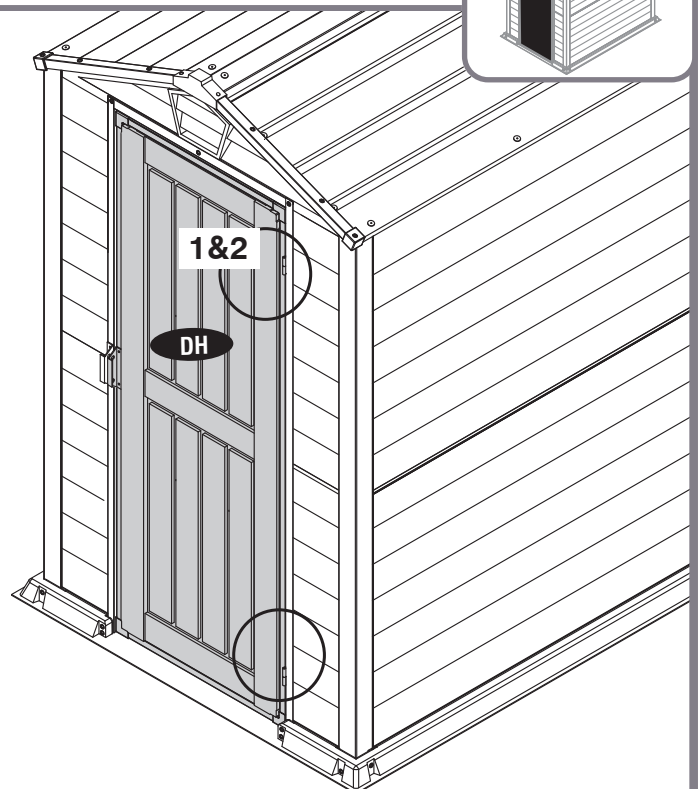

EN Assembly on Concrete Platform	CS Montáž na betonové plošině	IT Montaggio su piattaforma in calcestruzzo
FR Assemblage sur plate-forme en béton	SK Montáž na betónovú plošinu	PL Montaż na betonowej platformie
DE Montage auf Betonplattform	SL Montaža na betonsko ploščad	RO Adunarea pe platforma de beton
ES Montaje sobre la base de hormigón	HR Montaža na betonskoj platformi	BG Монтаж на бетонна платформа
PT Montagem em plataforma de concreto	HU Szerelés beton felületen	TR Beton platform üzerine montaj
NL Montage op betonplatform	SV Montering på betongplattform	



EN Parts needed	CS Potřebné součásti	IT Parti occorrenti
FR Pièces nécessaires	SK Potrebné časti	PL Niezbędne elementy
DE Benötigte Teile	SL Dele, ki jih boste potrebovali	RO Elementele componente necesare
ES Piezas necesitadas	HR Dijelovi potreban	BG Необходими части
PT Peças Necessárias	HU Szükséges részek	TR Gerekli parçalar
NL Onderdelen nodig	SV Delar som behövs	

S2	4
S6	4
F1	4



- EN** To ensure that your shed withstands high winds, we recommended to use this floor option. A concrete pad or a large size concrete patio stone squares is recommended for suitable floor base. Make sure it is firm and level and will allow drainage away from the site. Make a level concrete foundation, that has an outside dimension of 47 1/4" x 75" (1199mm x 1905mm).  
For a concrete pad base, prepare a level bed for a firm footing layer of crushed stone. The concrete pad should then be poured to a thickness of 4 inches (100mm) to 5 inches (125mm). Allow to dry thoroughly for at least 48 hours. Manufacturer is not responsible for the choice and construction of the foundation.  
Align the shed, make dia. 5.0mm holes on the base then mark the concrete through holes on the base and drill concrete with suitable concrete bit to accept Dia 6mm wall plug.
- FR** Pour vous assurer que votre hangar résiste à des vents violents, nous avons recommandé d'utiliser cette option de plancher. Une dalle de béton ou une grande taille concrètes dalles de patio de est recommandé pour base appropriée au sol. Assurez-vous qu'il est ferme et niveau et permettre un bon drainage du site. Faire niveau fondation en béton, qui a une dimension extérieure de 47 1/4" x 75" (1199mm x 1905mm).  
Pour une dalle en béton, préparer une couche de graviers de nive au. La dalle doit faire entre 10 et 12.5 cm. Le tampon de béton doit ensuite être coulé sur une épaisseur de 4 pouces (100 mm) à 5 pouces (125 mm). Laisser sécher complètement pendant au moins 48 heures. Le fabricant n'est pas responsable de la construction des fondations.  
Aligner le hangar, faire dia. 5,0mm trous sur la base puis marquer le béton à tr avers les trous sur la base et le béton de forage avec bit de béton approprié pour accepter Dia 6mm bouchon mural.
- DE** Um sicherzustellen, dass Ihr Schuppen hohen Winden standhält, empfiehlt es sich, diese Bodenoption zu benutzen. Eine konkrete Auflage oder eine große Größe konkreten Patio Stein Quadrate wird empfohlen für die geeignete Standring. Stellen Sie sicher, es ist fest und Ebene und Entwässerung von der Website ermöglicht. Machen Sie eine Ebene Betonfundament, die eine externe Dimension von 47 1/4" x 75" (1199mm x 1905mm).  
für eine konkrete Auflage hat base, einer soliden Basis Schicht aus Schotter ein Niveau Bett vorzubereiten. Die konkrete Auflage sollte dann zu einer Dicke von 4 Zoll (100 mm) bis 5 Zoll (125 mm) gegossen werden. Gründlich mindestens 48 Stunden trocknen lassen. Hersteller ist nicht verantwortlich für die Auswahl und Konstruktion der Stiftung.  
Richten Sie den Schuppen aus, bohren Sie Löcher mit einem Durchmesser von 5,0 mm in die Basis und markieren Sie die Beton-Durchgangslöcher in der Basis. Bohren Sie den Beton mit einem geeigneten Betonbohrer, um einen Dübel mit einem Durchmesser von 6 mm aufzunehmen.
- ES** Para asegurarse que su caseta resiste vientos fuertes le recomendamos usar esta opción de suelo. Tener una buena base de hormigón le dará más fuerza a la caseta. Asegúrese de colocar en un terreno perfectamente nivelado y que permita un correcto drenaje. Haga una base con un perímetro exterior con las siguientes medidas: 47 1/4" x 75" (1199mm x 1905mm). Cree el perímetro y coloque piedra para hormigonar en su interior, y eche el hormigón hasta una altura de entre 100mm y 125mm. Déjelo secar al menos 48 horas. El fabricante no es responsable de la construcción de la base de hormigón.  
Alinear el cobertizo, hacer dia. 5.0mm agujeros en la base a continuación, marque el hormigón a través de los agujeros en la base y taladre el hormigón con el bit de hormigón adecuado pa ra aceptar Dia 6mm tapón de pared.
- PT** Para garantir que o seu galpão resiste a ventos fortes, recomendamos usar esta opção de andar. Um bloco de concreto ou um quadrados de pedra de pátio de tamanho grande é recomendado para base apropriado do assoalho. Certifique-se que é firme e nivelada e permitirá drenagem longe do local. Fazer base de uma fundação de concreto nível, que tem uma dimensão exterior de 47 1/4" x 75" (1199mm x 1905mm).  
Em um bloco de concreto, preparar uma cama de nível para uma camada firme de brita. O base de concreto deve ser derramado emseguida a uma espessura de 4 polegadas (100mm), 5 polegadas (125mm). Deixe para secar completamente pelo menos 48 horas. Fabricante não é responsável pela escolha e construção da Fundação.  
Alinhe o galpão, faça furos com diâmetro de 5,0 mm na base e marque o concreto através dos furos na base e perfure o concreto com o bit de concreto adequado para aceitar o plugue de diâmetro de 6 mm.

**NL** Om ervoor te zorgen dat uw schuur bestand is tegen hoge winden, raden wij u aan deze vloeroptie te gebruiken. Een concrete pad of een groot formaat concrete patio stenen worden aanbevolen voor geschikt woord basis. Zorg ervoor dat het is stevig en niveau en drainage zal toestaan weg van de site. Een niveau concrete stichting, die een externe dimensie van 47 1/4" x 75" (1199mm x 1905mm).

Voor betonnen blok basis, bereid een gelijke vlakke voor e en vlak ondergrondslaag van keistenen. De betonnen blok moet dan worden gegoten tot een dikte van 4 inches (100 mm) tot 5 inches (125 mm). Laat het drogen tenminste 48uren. De bouwer is niet verantwoordelijk voor de keuze van constructie van de fundering.

Lijn het schuurtje uit, maak gaten met een diameter van 5,0 mm op de basis en markeer het beton door gaten in de basis en boor beton met een geschikte betonbeitel om een 6 mm muurplug te accepteren.

**CS** Abyste zajistili, že váš haly odolává silnému větru, doporučujeme použít tuto podlahu.

Pro vhodnou podlahovou základnu se doporučuje betonová podložka nebo velké betonové terasové čtverce. Ujistěte se, že je pevný a rovný a umožní odvodnění od místa. Vyrobté hladký betonový podklad, který má vnější rozměr 47 1/4" x 75" (1199mm x 1905mm).

U betonové podložky připravte rovnou lůžko pro pevnou podkladovou vrstvu drčeného kamene. Betonová vložka by měla být nalita do tloušťky od 100 palců do 5 palců (125 milimetrů). Nechte důkladně vyschnout po dobu nejméně 48 hodin. Výrobce nezodpovídá za volbu a výstavbu nadace.

Vyrovnejte kůlnu, na základně udělejte otvory o průměru 5,0 mm a poté označte betonové otvory na základně a vyvrtejte beton vhodným betonovým vrtákem, aby bylo možné přijmout průměr 6mm hmoždinky.

**SK** Aby ste zabezpečili, že vaša haly odolá vysokému vetru, odporúčame použiť túto podlahovú možnosť.

Na vhodnú podlahovú základňu sa odporúča betónová podložka alebo veľké betónové terasové štvorce. Uistite sa, že je pevný a rovný a umožní odvodnenie z miesta. Vytvorte základový betónový základ, ktorý má vonkajší rozmer 47 1/4" x 75" (1199mm x 1905mm).

Pre betónové podložky pripravte hladkú vrstvu pre pevnú základovú vrstvu drveného kameňa. Betónová podložka by mala byť potom naliatá do hrúbky 4 palce (100 mm) až 5 palcov (125 mm). Nechajte dôkladne vysušiť aspoň 48 hodín. Výrobca nie je zodpovedný za výber a výstavbu nadácie.

Zarovnajete kôľnu, na základni dajte priemer 5,0 mm a potom označte betón cez otvory na základni a vyvrťajte betón vhodným betónovým vrtákom, aby sa akceptoval priemer 6 mm hmoždinky.

**SL** Da bi zagotovili, da bo vaša hiša odtegnila visoke vetrove, smo priporočili, da uporabite to možnost.

Za primerne talne podlage je priporočljiva betonska podloga ali betonski trgi z velikimi površinami. Prepričajte se, da je čvrsta in raven ter omogočila drenažo stran od mesta. Izdelajte ravno betonsko podlago, ki ima zunanjo dimenzijo dimenzij 47 1/4"x75"(1199mm x1905mm).

Za betonsko podlago pripravite ravno posteljo za trdno podlago iz drobljenega kamna. Betonsko ploščo je treba nato vlititi do debeline 4 palcev (100 mm) do 5 palcev (125 mm). Pustite, da se temeljito posuši najmanj 48 ur. Proizvajalec ni odgovoren za izbiro in gradnjo temeljev.

Poravnajte skladišče, naredite odprtine premera 5,0 mm na dnu in nato označite beton skozi luknje na dnu in zvrtajte beton z ustreznim betonskim bitjem, da boste sprejeli stensko vtičnico premera 6 mm.

**HR** Da bismo osigurali da vaš prolaz izdrži jak vjetar, preporučujemo da upotrijebite tu podu.

Za pogodnu podnu bazu preporučuje se betonska podloga ili velike kamene ploče od betona. Pobrinite se da je čvrsta i razina i omogućiti će odvod daleko od stranice. Izradite temeljni betonski temelj koji ima vanjsku dimenziju od 47 1/4" x 75" (1199mm x 1905mm).

Za betonsku podlogu, pripremite krevet na razini za čvrsto podnožje slomljenog kamena. Betonsku podlogu treba zatim izliti na debljinu od 100 mm do 125 inča. Ostavite temeljito suhom najmanje 48 sati. Proizvođač nije odgovoran za odabir i izgradnju zaklade.

Poravnajte šupu, napravite rupe promjera 5,0 mm na postolju, zatim označite beton kroz rupe na bazi i izbušite beton odgovarajućim komadom betona da biste prihvatili zidni utikač promjera 6 mm.

**HU** Annak érdekében, hogy a fészker ellenálljon a magas szeleknek, javasoljuk, hogy használja ezt a padlót.

Betonpárna vagy nagyméretű betonpadló köpadok ajánlottak megfelelő padlóalakra. Győződjön meg arról, hogy szilárd és vízszintes, és lehetővé teszi a vízelvezetést távol a helyszíntől. Végezzünk el egy szintetikus alapot, amely 47 1/4" x 75" (1199mm x 1905mm).

Betonpárnás aljzat esetén készítsen egy szintes ágyat egy szilárd alapozórétegre. A betonpárnát ezután 100 mm-es és 125 mm-es vastagságúra kell önteni. Legalább 48 órán keresztül hagyja alaposan száradni. A gyártó nem vállal felelősséget az alapítvány kiválasztásához és megépítéséért.

Igazítsa a fészket, helyezze át az átmérőjű 5,0 mm-es lyukakat az alaplapon, majd jelölje meg a betont az alaplapon lévő lyukakon, és fúrjon be betont a megfelelő betonbevonattal, hogy elfogadja a 6 mm-es átmérőjű fali dugót.

**SV** För att säkerställa att din skjul får hög vind rekommenderar vi att du använder det här golvalternativet.

En betongkudde eller en stor betongplattform rekommenderas för lämplig golvyta. Se till att den är fast och jämn och gör det möjligt att dränera bort från platsen. Gör en jämn betongfundament, som har en yttre dimension av 47 1/4" x 75" (1199mm x 1905mm).

För en betongplatta bas, förbereda en nivå säng för ett fast fotskikt av krossad sten. Betongplattan ska sedan hållas till en tjocklek av 4 tum (100 mm) till 5 tum (125 mm). Låt torka noggrant i minst 48 timmar. Tillverkaren ansvarar inte för valet och byggandet av stiftelsen.

Rikta ut skuren, gör hål på 5,0 mm i basen och markera betongens genomgående hål på botten och borra betong med lämplig betongbit för att ta emot 6 mm väggplugg.

**IT** Per garantire che il tuo capannone sopporta venti elevati, abbiamo consigliato di utilizzare questa opzione a pavimento.

Si consiglia un tappetino in calcestruzzo o un quadrato in pietra di cemento in grande formato per una base adatta. Assicurarsi che sia stabile e livellato e permetterebbe di drenare lontano dal sito. Realizzare una base di calcestruzzo di livello, che ha una dimensione esterna di 47 1/4" x 75" (1199mm x 1905mm).

Per una base di rilievo in calcestruzzo, preparare un letto a livello per un solido strato di pietra schiacciata. Il tappetino di calcestruzzo deve quindi essere versato ad uno spessore da 100 mm a 125 centimetri. Lasciare asciugare accuratamente per almeno 48 ore. Il produttore non è responsabile della scelta e della costruzione della fondazione.

Allineare il capannone, praticare fori di diametro 5,0 mm sulla base, quindi contrassegnare i fori passanti del calcestruzzo sulla base e forare il calcestruzzo con una punta di cemento adatta per accettare il tappo a muro del diametro di 6 mm.

**PL** W celu zapewnienia, że szopy wytrzymują wysokie wiatry, zalecamy skorzystanie z tej opcji podłogi.

Betonu pad lub duży rozmiar konkretne patio kamień kwadratów jest zalecane dla odpowiedniej bazy piętro. Upewnij się, że to jest prosto i stabilnie i pozwoli drenaż wlotny. Zrobić fundamenty betonowym poziom, który ma wymiar zewnętrzny 47 1/4" x 75" (1199mm x 1905mm).

Do betonu pad podstawy, przygotować łóżko poziom dla firmy stopie warstwę tłuczni. Betonu pad powinien być następnie przelewa się do grubości 4 cali (100mm) do 5 cali (125mm). Pozostawić do wyschnięcia dokładnie na co najmniej 48 godzin. Producent nie jest odpowiedzialny za wybór i budowie fundamentów.

Wyrównaj szopę, wykonaj otwory o średnicy 5,0 mm na podstawie, a następnie zaznacz betonowe otwory w podstawie i wywierć beton odpowiednim bitem betonowym, aby przyjąć kołek ścienny o średnicy 6 mm.



**RO** Pentru a vă asigura că vaporul dvs. rezistă unor vânturi puternice, am recomandat să folosiți această opțiune pentru podea. Un tampon de beton sau o pătrată de piatră din beton de dimensiuni mari este recomandată pentru o bază adecvată pentru podea. Asigurați-vă că este ferm și la nivel și va permite scurgerea departe de site. Asigurați o fundație de beton de nivel, care are o dimensiune exterioară de 47 1/4" x 75"(1199mm x 1905mm).

Pentru o bază de bază de beton, pregătiți un pat de nivel pentru un strat ferm de piatră zdrobită. Plăcuța de beton trebuie apoi turnată la o grosime de 4 inci (100 mm) până la 5 inci (125 mm). Lăsați-l să se usuce bine timp de cel puțin 48 de ore.

Producătorul nu este responsabil pentru alegerea și construirea fundației.

Aliniați magazia, faceți diametrul de 5,0 mm pe bază, apoi marcați betonul prin orificiile de pe bază și forțați betonul cu un bit adecvat de beton pentru a accepta un diametru de 6 mm.

**BG** За да сте сигурни, че Вашата барака издържа високи ветрове, препоръчваме да използвате тази опция за пода.

За подходяща подова основа се препоръчва използването на бетонна подложка или големи бетонни квадратни плочки. Уверете се, че тя е здрава и равна и ще позволи дренаж далеч от мястото. Направете нивелирана бетонна основа, която има външен размер от 47 1/4" x 75"(1199mm x 1905mm).

За бетон основа на подложка, подгответе ниво легло за твърда основа слой от натрошен камък. След това бетонната подложка трябва да се излива на дебелина от 4 инча (100 мм) до 5 инча (125 мм). Оставете да изсъхне напълно за поне 48 часа. Производителят не носи отговорност за избора и изграждането на основата.

Подравнете навеса, направете отвори с диаметър 5.0 мм на основата, след което маркирайте бетона през отворите на основата и пробийте бетон с подходящ бетонен бит, за да приемете щепсел с диаметър 6 мм.

**TR** Sunduğunuzdan yüksek rüzgarlara dayanıklı olmasını sağlamak için bu zemin seçeneğini kullanmanızı öneririz.

Uygun taban tabanı için beton bir yastık veya büyük boy bir beton bahçe avlusu karosu önerilir. Sert ve sağlam olduğundan ve drenajın yerinden uzaklaşmasına izin vereceğinden emin olun. Basic Shed için dış boyut 47 1/4" x 75"(1199mm x 1905mm).

Beton pad taban için, ezilmiş taştan sağlam bir taban tabakası için düz bir yatak hazırlayın. Beton pedi daha sonra 4 inç (100mm) ile 5 inç (125mm) arasındaki bir kalınlığa dökülmelidir. En az 48 saat boyunca iyice kurumasına izin verin. Üretici, vakfın seçimi ve yapımı için sorumlu değildir.

Kanadı hizalayın, tabanda 5.0 mm delikler açın, daha sonra tabanda delikler arasından betonu işaretleyin ve 6 mm çaplı dübel çapını kabul etmek için betonu uygun bir beton bit ile açın.



F1 (x4)



S2 (x4)



S6 (x4)

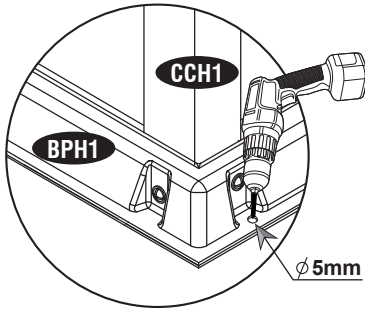

1

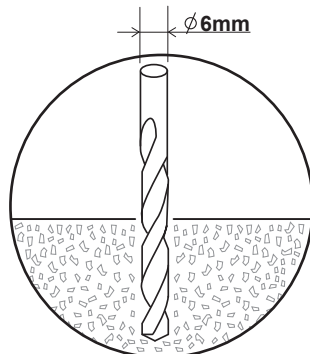

2

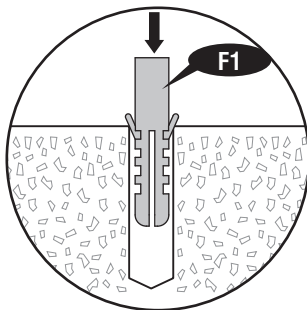

3

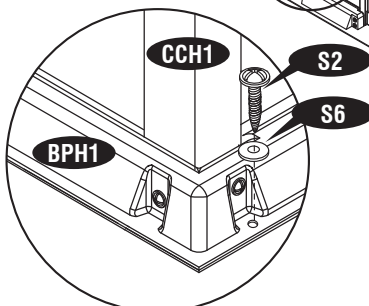

4

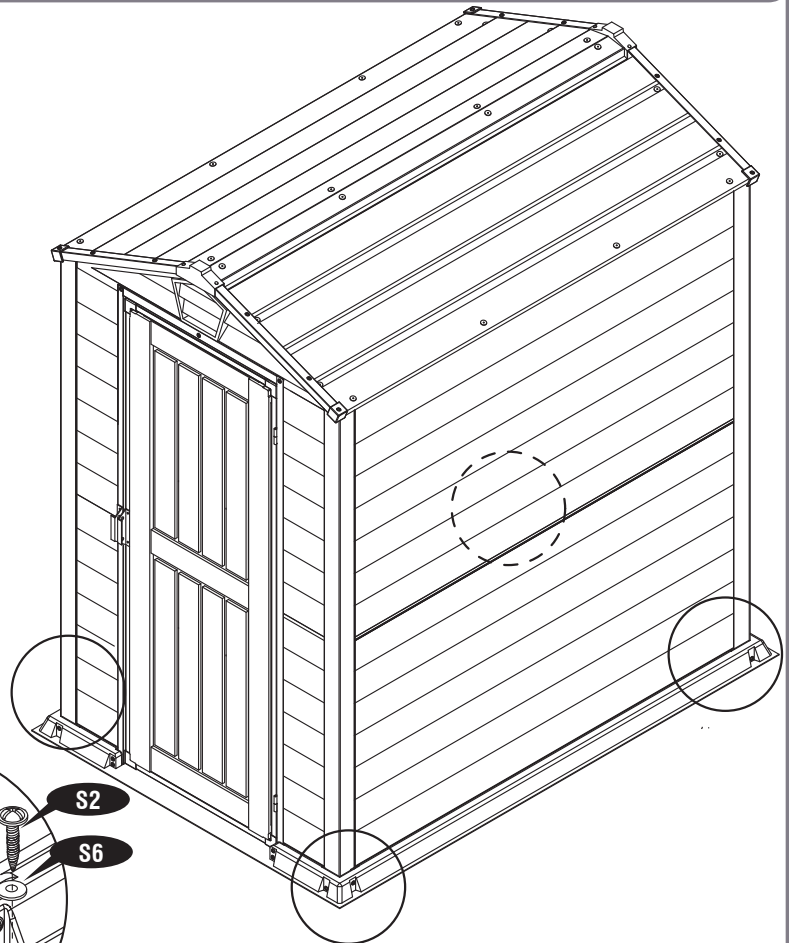

EN Important Warranty Information

FR Informations Importantes Concernant La Garantie

DE Wichtige Informationen zur Gewährleistung

ES Información importante sobre la garantía

PT Importantes Informações de Garantia

NL Belangrijke Informatie over de garantie

CS Důležité informace o záruce

SK Dôležité informácie o záruke

SL Pomembne Garancijske Informacije

HR Važne informacije o jamstvu

HU Fontos jótállási információk

SV Viktig garantiinformation

IT Informazioni importanti sulla garanzia

PL Ważne informacje gwarancyjne

RO Informații importante privind garanția

BG Важна информация за гаранцията

TR Önemli Garanti Bilgileri



EN The 'DURAMAX' shed has been tested and passed high wind loads in a controlled laboratory environment when installed with the high wind installation guidelines. Natural high wind areas create wind at unpredictable speeds that are very difficult to capture accurately by location. As such we cannot guarantee the performance of the shed in these extreme situations

FR Le hangar 'DURAMAX' a été testé et passé des charges de vent élevées dans un environnement de laboratoire contrôlé lorsqu'il est installé avec les directives d'installation de haute vent. Naturelles, les zones de vents forts créent vent à des vitesses imprévisibles qui sont très difficiles à saisir avec précision par emplacement. En tant que tel, nous ne pouvons pas garantir la performance de la foule dans ces situations.

DE Das "DURAMAX" -Haus wurde getestet und hat hohe Windlasten in einer kontrollierten Laborumgebung bestanden, wenn es mit den Richtlinien für hohe Windinstallationen installiert wurde. Natürliche Starkwindgebiete erzeugen Wind mit unvorhersehbaren Geschwindigkeiten, die aufgrund des Standorts nur schwer erfasst werden können. Daher können wir die Leistung des Schuppens in diesen extremen Situationen nicht garantieren.

ES La caseta 'DURAMAX' ha sido probada y aprobado para cargas de viento en un entorno controlado de laboratorio, cuando se instala con las pautas de instalación de vientos fuertes. Espacios naturales de vientos crean viento a velocidades impredecibles que son muy difíciles de capturar con precisión la ubicación. Por lo tanto, no podemos garantizar el correcto funcionamiento de la caseta en tales situaciones extremas.

PT O galpão 'DURAMAX' foi testado e passou por altas cargas de vento em um ambiente de laboratório controlado quando instalado com as diretrizes de instalação de alta energia eólica. As áreas naturais de ventos fortes criam vento a velocidades imprevisíveis que são muito difíceis de capturar com precisão por localização. Como tal, não podemos garantir o desempenho do galpão nessas situações extremas

NL Het 'DURAMAX'-schuurtje is getest en heeft hoge windbelastingen doorstaan in een gecontroleerde laboratoriumomgeving, indien geïnstalleerd met de richtlijnen voor hoge winden. Natuurlijke windrijke gebieden creëren wind met onvoorspelbare snelheden die zeer moeilijk nauwkeurig op locatie kunnen worden vastgelegd. Als zodanig kunnen we de prestaties van de schuur in deze extreme situaties niet garanderen

CS Ústředna DURAMAX byla testována a prošla vysokým zatížením větrem v kontrolovaném laboratorním prostředí, když byla instalována s pokyny pro větrnou instalaci. Přírodní větrné plochy vytvářejí vítr při nepředvídatelných rychlostech, které je velmi obtížné přesně zachytit podle místa. Jako takové nemůžeme zaručit výkon haly v těchto extrémních situacích

SK Dúchadlá "DURAMAX" boli testované a prešli vysokou záťažou vetra v kontrolovanom laboratórnom prostredí, keď sú inštalované so smernicami pre vysoký vietor. Prírodné vetrné plochy vytvárajú vietor pri nepredvídateľných rýchlostiach, ktoré sa veľmi ťažko zachytia presne podľa miesta. Ako taký nemôžeme zaručiť výkonnosť kôlne v týchto extrémnych situáciách

SL Preskus "DURAMAX" je bil preizkušen in prešel velike obremenitve vetra v nadzorovanem laboratorijskem okolju, če je bil nameščen s smernicami za visoko vetrove. Naravni viri vetra ustvarijo veter ob nepredvidljivih hitrostih, ki jih je zelo težko natančno zajemati glede na lokacijo. Kot taka ne moremo zagotoviti učinkovitosti skladišča v teh skrajnih razmerah

HR Prostor "DURAMAX" je testiran i prošao velike opterećenja vjetrom u kontroliranom laboratorijskom okruženju kada je instaliran s visokim smjernicama za instalaciju vjetra. Prirodni visoki vjetrovi stvaraju vjetar na nepredvidljivim brzinama koje su vrlo teško točno snimiti po lokaciji. Kao takav ne možemo jamčiti izvedbu prolivenih u ovim ekstremnim situacijama

HU A DURAMAX fészerét ellenőrzött laboratóriumok környezetben tesztelték, és nagy szélterhelést vezettek be, amikor a nagy szélsőkapási irányelvekkel telepítették. A természeti nagy szélterületek olyan kiszámíthatatlan sebességű szélsősebességű hoznak létre, amelyet nagyon nehéz rögzíteni helyesen a helyszínen. Így nem garantálhatjuk a fészer teljesítményét ebben a szélsőséges helyzetben

SV DURAMAX-skjulet har testats och passerat höga vindbelastningar i en kontrollerad laboratoriemiljö när den installeras med riktlinjerna för hög vindkraft. Naturliga höga vindområden skapar vind med oförutsägbara hastigheter som är mycket svåra att fånga noggrant på plats. Som sådan kan vi inte garantera skurets prestanda i dessa extrema situationer

IT Il capannone 'DURAMAX' è stato testato e ha superato carichi di vento elevato in un ambiente di laboratorio controllato quando installato con le linee guida per l'installazione del vento forte. Le aree naturali del vento forte creano vento a velocità imprevedibili che sono molto difficili da catturare con precisione in base alla posizione. Pertanto non possiamo garantire le prestazioni del capannone in queste situazioni estreme





- PL** Szopa "DURAMAX" została przetestowana i przeszła duże obciążenia wiatrem w kontrolowanym środowisku laboratoryjnym, gdy zainstalowano ją zgodnie z wytycznymi dotyczącymi instalacji wiatrowej. Naturalne obszary o dużym natężeniu wiatru wytwarzają wiatr o nieprzewidywalnych prędkościach, które są bardzo trudne do uchwycenia dokładnie według lokalizacji. W związku z tym nie możemy zagwarantować wykonania szopy w tych ekstremalnych sytuacjach.
- RO** Dulapul "DURAMAX" a fost testat și a fost încercat cu încercături puternice de vânt într-un mediu de laborator controlat atunci când este instalat cu instrucțiunile de instalare a vântului. Zonele naturale cu vânt puternic creează vânt la viteze imprevizibile, care sunt foarte greu de capturat cu precizie în funcție de locație. Ca atare, nu putem garanta performanța magazinului în aceste situații extreme
- BG** Тръбопроводът "DURAMAX" е тестван и преминава в силно натоварване от вятър в контролирана лабораторна среда, когато е инсталиран с насоките за вятърна инсталация. Природните високи ветрови зони създават вятър при непредсказуеми скорости, които са много трудни за улавяне по точно местоположение. Като такива не можем да гарантираме изпълнението на навеса в тези крайни ситуации
- TR** "DURAMAX" dökümü, yüksek rüzgar tesisatı kurallarına göre kurulduğunda kontrollü bir laboratuvar ortamında yüksek rüzgar yüklerini test etti ve geçti. Doğal yüksek rüzgarlı bölgeler, konuma göre hassas bir şekilde yakalanması çok zor olan, öngörülemeyen hızlarda rüzgar yaratır. Bu nedenle, bu olağanüstü durumlarda kulübemin performansını garanti edemeyiz.



- EN** "For dismantling the Shed, Customer has to follow instructions manual in reverse direction."
- FR** "Pour le démantèlement du hangar, client doit suivre le manuel d'instructions dans le sens inverse."
- DE** In Gebieten mit starken Schneefällen oder starkem Wind empfehlen wir das nachstehende Zubehör.
- ES** "Para el desmantelamiento de la nave, cliente tiene que seguir instrucciones en sentido contrario".
- PT** "Para desmontar o galpão, cliente tem de seguir o manual de instruções em sentido reverso".
- NL** "Voor de ontmanteling van de schuur, klant heeft te volgen instructiehandleiding in omgekeerde richting."
- CS** 'Pro demontáž přístřešku musí zákazník postupovat podle pokynů v opačném směru.'
- SK** 'Pri demontáži prístrešku musí zákazník postupovať podľa pokynov v opačnom smere.'
- SL** 'Za demontažo skladišča mora naročnik slediti priročniku v obratni smeri.'
- HR** 'Za demontažu zida, korisnik mora slijediti priručnike za upute u obrnutom smjeru.'
- HU** 'A fészert lebontásához az Ügyfélnek vissza kell követnie az utasításokat.'
- SV** 'För att demontera Shed måste kunden följa instruktionsboken i omvänd riktning.'
- IT** 'Per lo smontaggio del capannone, il cliente deve seguire manualmente le istruzioni in senso inverso'..
- PL** do demontażu szopy, należy postępować zgodnie z instrukcją obsługi w odwrotnym kierunku
- RO** 'Pentru dezmembrarea Shedului, Clientul trebuie să urmeze manualul de instrucțiuni în sens invers.'
- BG** 'За демонтиране на навеса клиентът трябва да следва инструкциите в наръчник в обратна посока.'
- TR** 'Shed'in sökülmesi için, Müşteri yönergeleri ters yönde takip etmelidir.'



**EN** ADDITIONAL ACCESSORIES AVAILABLE  
(Not included)

**FR** ACCESSOIRES ADDITIONNELS DISPONIBLES  
(non inclus)

**DE** WEITERES ZUBEHÖR  
(Nicht enthalten)

**ES** ACCESORIOS ADICIONALES DISPONIBLES  
(no incluida)

**PT** ACESSÓRIOS ADICIONAIS DISPONÍVEIS  
(não incluído)

**NL** EXTRA ACCESSOIRES AANWEZIG.  
(niet inbegrepen)

**CS** MOŽNÉ DALŠÍ DOPLŇKY.  
(není součástí balení)

**SK** DOSTUPNÉ DODATOČNÉ PRÍSLUŠENSTVO  
(nie je súčasťou balenia)

**SL** RAZPOLOŽLJIVA DODATNA OPREMA  
(niso vključene)

**HR** DODATNI PROGRAMI RASPOLOŽIV  
(nije uključeno)

**HU** TOVÁBBI MEGVÁSÁROLHATÓ TARTOZÉKOK  
(nem tartozék)

**SV** YTTERLIGARE TILLGÄNGLIGA ACCESSOARERV  
(ingår ej)

**IT** ACCESSORI SUPPLEMENTARI DISPONIBILI  
(non incluso)

**PL** DOSTĘPNE DODATKOWE AKCESORIA  
(nie wliczone)

**RO** ACCESORIILE SUPLIMENTARE DISPONIBILE  
(Nu este inclus)

**BG** ДОПЪЛНИТЕЛНИ НАЛИЧНИ АКЕСОАРИ  
(не е включен)

**TR** EK AKSESUARLAR MEVCUTTUR  
(dahil değildir)



**EN** These accessories are required in case of heavy snow or high wind areas.  
Please choose relevant accessories according to your needs.

**FR** Ces accessoires sont exigés en cas de zones de la neige forte ou du vent fort.  
Veuillez choisir les accessoires appropriés selon vos besoins.

**DE** In Gebieten mit starken Schneefällen oder starkem Wind empfehlen wir das nachstehende Zubehör.

**ES** Estos accesorios son requeridas en caso de fuertes nevadas o zonas de alto viento.  
Por favor, elija los accesorios pertinentes de acuerdo a sus necesidades.

**PT** Estes acessórios são necessários em áreas de vento forte e/ou neve.  
Por favor, escolha os acessórios pertinentes de acordo com suas necessidades.

**NL** Deze accessoires zijn nodig in geval van hevige sneeuw val of gebieden waar het hard waait.  
Gebruik de accessoires die u nodig heeft.

**CS** Tyto doplňky se vyžadují v místech s velkým množstvím sněhu či silným větrem.  
Zvolte si prosím příslušné doplňky podle vašich potřeb.

**SK** Toto príslušenstvo sa vyžaduje v prípadoch ťažkého a veľkého množstva snehu alebo silného vetra.  
Vyberte si relevantné príslušenstvo na základe vašich potrieb.

**SL** Ta dodatna oprema se uporablja v primeru velike količine zapadlega snega ali če lopa stoji na zelo vetrovnem območju.  
Izberite ustrezno opremo glede na to, kaj dejansko potrebujete.

**HR** Ovi dodaci su potrebni u slučaju teškog snijega ili jak vjetar regija. Molimo odaberite relevantne dodatne opreme prema vašim potrebama.

**HU** Ezekre a tartozékokra sürű havazás esetén vagy erősen szeles területeken van szükség. Kérjük, igénye szerint válasszon a megfelelő tartozékok közül.

**SV** Dessa accessoarer behövs vid tung snö eller i områden med hård vind.  
Var god välj relevanta accessoarer efter behov.

**IT** Questi accessori sono importanti in caso di neve o aree soggette a forti venti. Per favore, scegli questi accessori in base ai tuoi bisogni.

**PL** Akcesoria te są wymagane w przypadku terenów, na których zdarzają się duże opady śniegu lub silnewiatry. Wybierz odpowiednie akcesoria w zależności od potrzeb.

**RO** Aceste accesorii sunt necesare în cazul în cazul în care apar depuneri masive de zăpadă sau în zonele în care bate vânt puternic. Vă rugăm alegeți accesorii potrivite nevoilor dumneavoastră.

**BG** Тези аксесоари се изискват в случай на тежък сняг или при райони със силен вятър. Моля подберете съответните аксесоари според нуждите.

**TR** Bu aksesuarlar yoğun kar yağışı ya da kuvvetli rüzgar alan bölgelerde gereklidir. Lütfen ihtiyaçlarınıza uygun gerekli aksesuarları seçiniz.

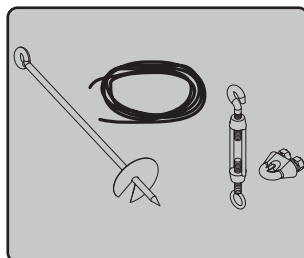

1

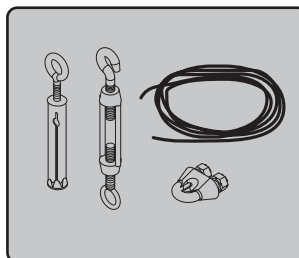

2

1

- |                                    |                                |
|------------------------------------|--------------------------------|
| EN ANCHOR KIT (Soil)               | HR SIDRO KOMPLET (tla)         |
| FR KIT D'ANCRE (Sol)               | HU RÖGZÍTŐ FELSZERELÉS (Talaj) |
| DE ANKER-KIT (Boden)               | SV FÖRANKRINGS-KIT (Jord)      |
| ES KIT DE ANCLAJE (Suelo)          | IT KIT DI ANCORAGGIO (Suolo)   |
| PT KIT DE APOIO (Solo)             | PL ZESTAW DO MOCOWANIA (Grunt) |
| NL ANKER GEREEDSCHAP (bodem)       | RO SET DE ANCORARE (ÎN SOL)    |
| CS KOTEVNÍ SOUPRAVA (Hlína)        | BG КОМПЛЕКТ АНКЕРИ (Почва)     |
| SK UKOTVOVACIE PRÍSLUŠENSTVO (zem) | TR EKLEMLEME KİTİ (Toprak)     |
| SL SIDRNA OPREMA (zemlja)          |                                |

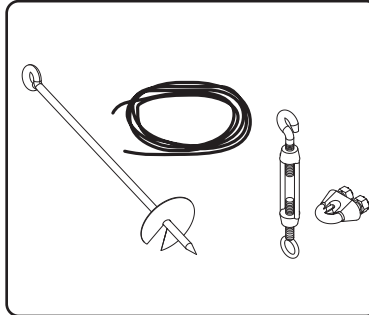

- EN Wire rope with twist augers for sheds installed with foundation (Wood / Metal) on soil.  
**For heavy wind area.**
- FR Fil de fer avec des foreuses de torsion pour des hangars installés avec la base (en métal / en bois) sur le sol. **Pour la zone du vent fort.**
- DE Seil mit Erdbohrer bei einem Unterbau (Holz / Metall) auf dem Boden.  
**Für Gebiete mit starkem Wind.**
- ES El cable metálico para casetas instaladas con kit de estructura de suelo fijada al terreno
- PT Cabo metálico com brocas para galpões instalados com base (Madeira/Metal) em solo.  
**Para áreas de vento forte.**
- NL Bedrading met kronkelige grondboren voor het schuurtje moet met fundering worden geïnstalleerd (hout/metaal) op bodem. **Voor hevige wind gebieden.**
- CS Drátěné lano se vrtáky pro kůlny postavené se základy (dřevo / kov) na hlíně.  
**Pro místa se silným větrem.**
- SK Drôtené lano s krútenými špirálovitými šnekmi pre hangáre nainštalované zo základom (drevo/kov) na zemi. **Pre oblasť so silným vetrom.**
- SL Žična vrv z velikim svedom z enojno spiralo za lope nameščene na temelju (les/kovina) na zemlji.  
**Za zelo vetrovna območja.**
- HR čelikčelo s okretati svrdlom za baca instaliran s temelja (Drvo / Metal) na tlu.  
**Za teške vjetar području.**
- HU Drótkötél spirálfúrókkal alappal rendelkező kerti fészerekhez (Fa / fém) talajon.  
**Erősen szeles területekre.**
- SV Wirelås med tvistborr för skjul installerade med grund (trä / metall) på jord.  
**För områden med hård vind.**
- IT Fune con trivella a spirale per capannoni installati con fondamenta (legno/metallo) sul suolo.  
**Per aree soggette a forte vento.**
- PL Lina stalowa ze świdrami dla magazynków montowanych na pod stawie (Drewno/Metal) do gruntu.  
**Przeznaczone do użytkowania na obszarach występowania silnych wiatrów.**
- RO Cabluri cu burghie răsucite pentru magaziile asamblate pe fundație (Lemn / Metal) în sol.  
**Pentru zonele în care bate vânt puternic.**
- BG Стоманено въже с извити сонди за заслони, монтирани върху фундаменти (Дърво / Метал) върху почва.  
**За силно ветровита зона.**
- TR Zemin (tahta/metal) toprak üstüne gelecek şekilde inşa edilen barnaklar için burgulu matkap ve tel ip.  
**Kuvvetli rüzgar alan yerler için.**



2

EN ANCHOR KIT (Concrete)

FR KIT D'ANCRE (Béton)

DE Verankerungsset (Beton)

ES KIT DE ANCLAJE (hormigón)

PT KIT DE APOIO (Concreto)

NL ANKER GEREEDSCHAP (Beton)

CS KOTEVNÍ SOUPRAVA (Beton)

SK UKOTVOVACIE PRÍSLUŠENSTVO (betón)

SL SIDRNA OPREMA (beton)

HR SIDRO KOMPLET (beton)

HU RÖGZÍTŐ FELSZERELÉS (Beton)

SV FÖRANKRINGS-KIT (Betong)

IT KIT DI ANCORAGGIO (cemento)

PL ZESTAW DO MOCOWANIA (Beton)

RO SET DE ACORARE (Beton)

BG КОМПЛЕКТ АНКЕРИ (Бетон)

TR EKLEMLEME KİTİ (Beton)

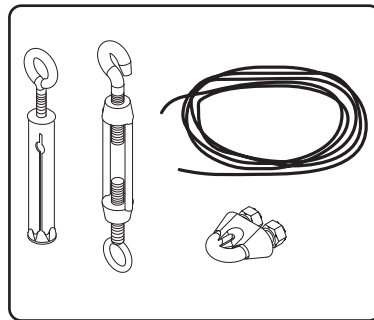

EN Eye bolt with wire rope for sheds installed with foundation (Wood / Metal) on concrete.  
**For heavy wind area.**

FR OEil à queue filetée avec fil en fer pour des hangars installés avec la base (en métal / en bois) sur le béton.  
**Pour la zone du vent fort.**

DE Ringschraube mit Seil für Gerätehäuser mit einem Unterbau (Holz / Metal) auf Beton.  
**Für Gebiete mit starkem Wind.**

ES Coloque pernos de ojo y el cable metálico para las zonas de fuerte viento.  
**Para el área del fuerte viento.**

PT Caviilha com cabo de aço para galpões instalados com base (Madeira/Metal) em concreto.  
**Para áreas de vento forte.**

NL Eyebolt met stalendraad voor schuurtje moet worden geïnstalleerd met fundering (hout/metaal) op beton.  
**Voor hevige wind gebieden.**

CS Oka s drátěným lanem pro kůlny postavené se základy (dřevo / kov) na betonu.  
**Pro místa se silným větrem.**

SK Šrob s okom s drôtovým lanom pre hangáre nainštalované so základom (drevo/kov) na betóne.  
**Pre oblasť so silným vetrom.**

SL Očesni vijak z žično vrvjo za lope nameščene na temelju (les/kovina) na betonu.  
**Za zelo vetrovna območja.**

HR oči vijak žičane užadi za baca Installer sa temelja (Drvo / Metal) na betonu.  
**Za teške vjetar području.**

HU Gyűrűs csavar drótkötélel alappal rendelkező kerti fészerekhez (Fa / fém) betonon.  
**Erősen szeles területekre.**

SV Stagögla med wirelås för skjul som installerats med grund (Trä / Metall) på betong.  
**För områden med hård vind.**

IT Vite ad occhio con fune per capannoni installati con fondamenta (legno/metallo) sul cemento.  
**Per aree soggette a forte vento.**

PL Śruba z uchem z liną stalową dla magazynków montowanych na podstawie (Drewno/Metal) do betonu.  
**Przeznaczone do użytkowania na obszarach występowania silnych wiatrów.**

RO Șurub cu ochi atașat la un cablu pentru magazine asamblate pe fundație (Lemn / Metal) în beton.  
**Pentru zonele în care bate vânt puternic.**

BG Шарнирен болт със стоманено въже за заслони, инсталирани с фундамент (Дърво / Metal) върху бетон.  
**За силно ветровита зона.**

TR Zemin (tahta/metal) beton üstüne gelecek şekilde inşa edilen barınaklar için halkalı vida ve tel ip.  
**Kuvvetli rüzgar alan yerler için.**



U.S. Polymers, Inc.  
1057 S. Vail Ave  
Montebello, CA 90640,  
United States of America

[www.duramaxbp.com](http://www.duramaxbp.com)