

303-2

11-21

- Montageanleitung -

(bitte zusammen mit dem Kaufbeleg aufbewahren)

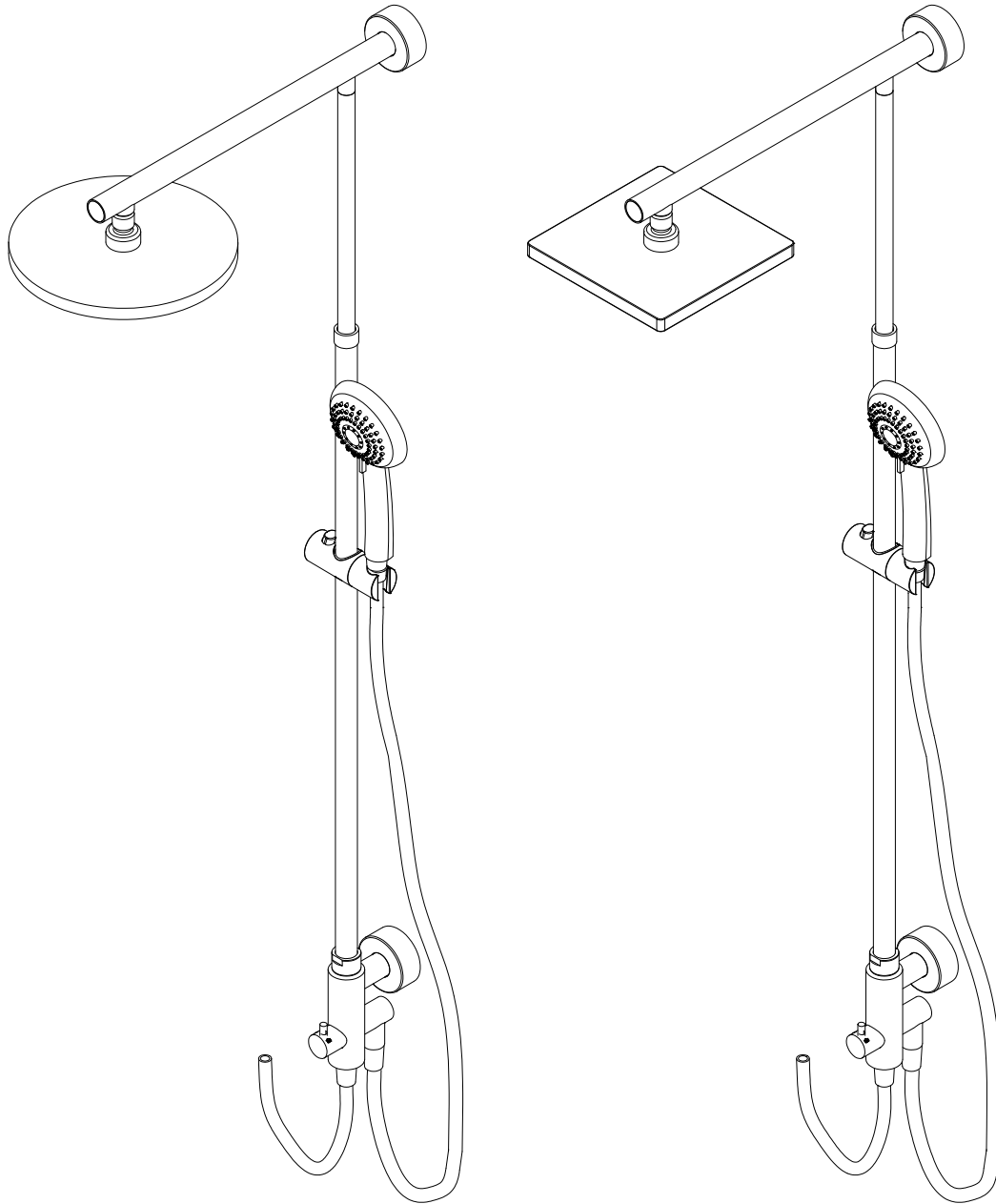

- Assembly instructions -

(please retain and file together with the purchase receipt)

- Notice de montage -

(à conserver et à accrocher impérativement avec le justificatif d'achat)

- Montagehandleiding -

(samen met de aankoopfactuur in ieder geval bewaren)

Maßzeichnung, dimensional drawing, dimensions, maatekening

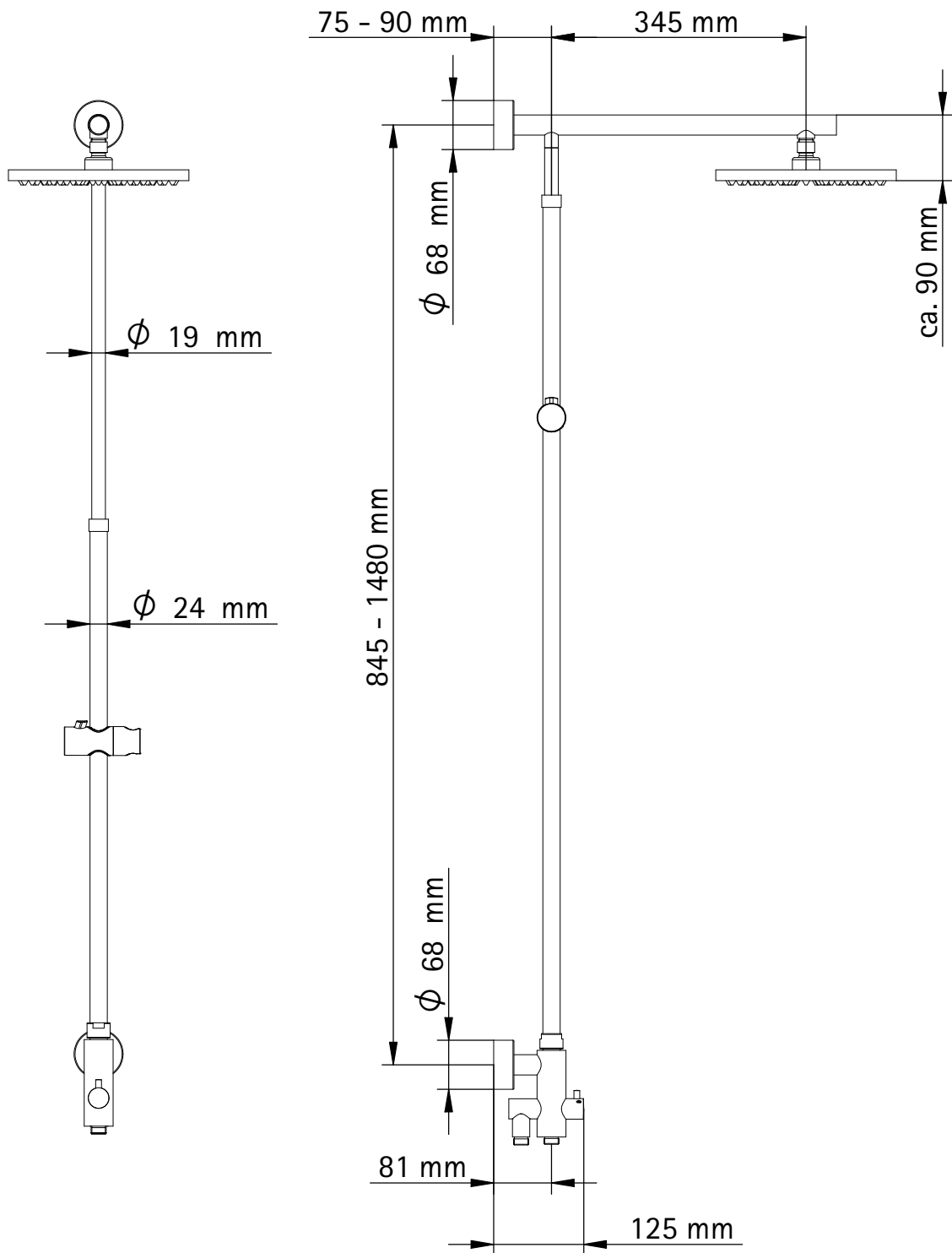

Info

- de** Alle Maßangaben unterliegen einer Toleranz von ± 5 mm
- en** All dimensions are subject to a tolerance of ± 5 mm
- fr** Toutes les mesures sont soumises à une tolérance de ± 5 mm
- nl** Leder maatopgaaf heeft een tolerantie van ± 5 mm

Ersatzteilübersicht, spare parts overview, aperçu des pièces détachées, onderdelen overzicht

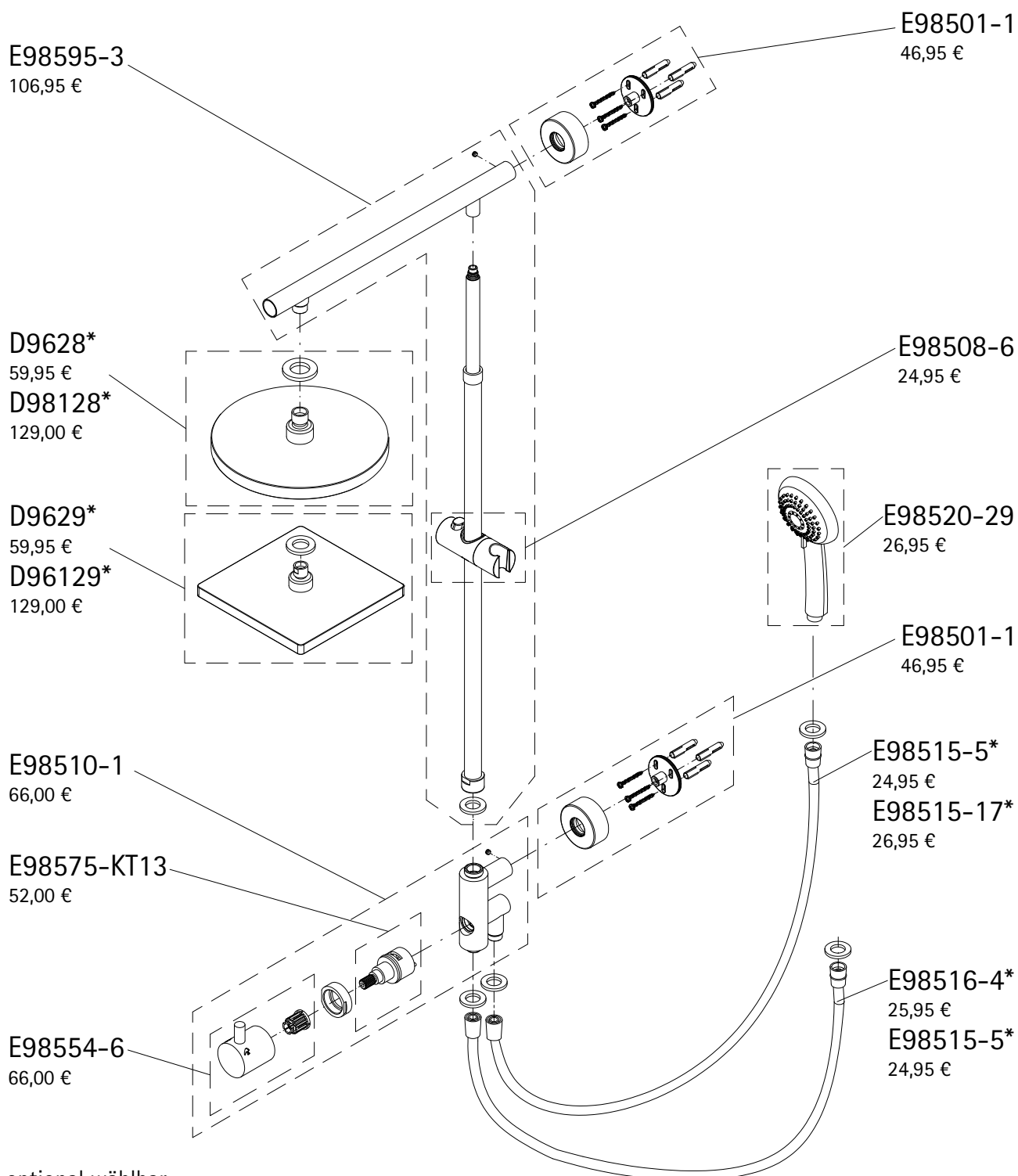

* optional wählbar

Info

de Bei der Ersatzteilbestellung bitte unbedingt die entsprechende Artikelnummer vom Kaufbeleg angeben

en When ordering spare parts, please specify the item on the order from.

fr Lors de la commande des pièces détachées veuillez donner le numéro d'article conforme au bon d'achat.

nl Bij de onderdelenbestelling graag in elk geval het passende artikelnummer van het koopbewijs aangeven.

Benötigtes Werkzeug, Tools required, Outils nécessaires, Benodigd gereedschap

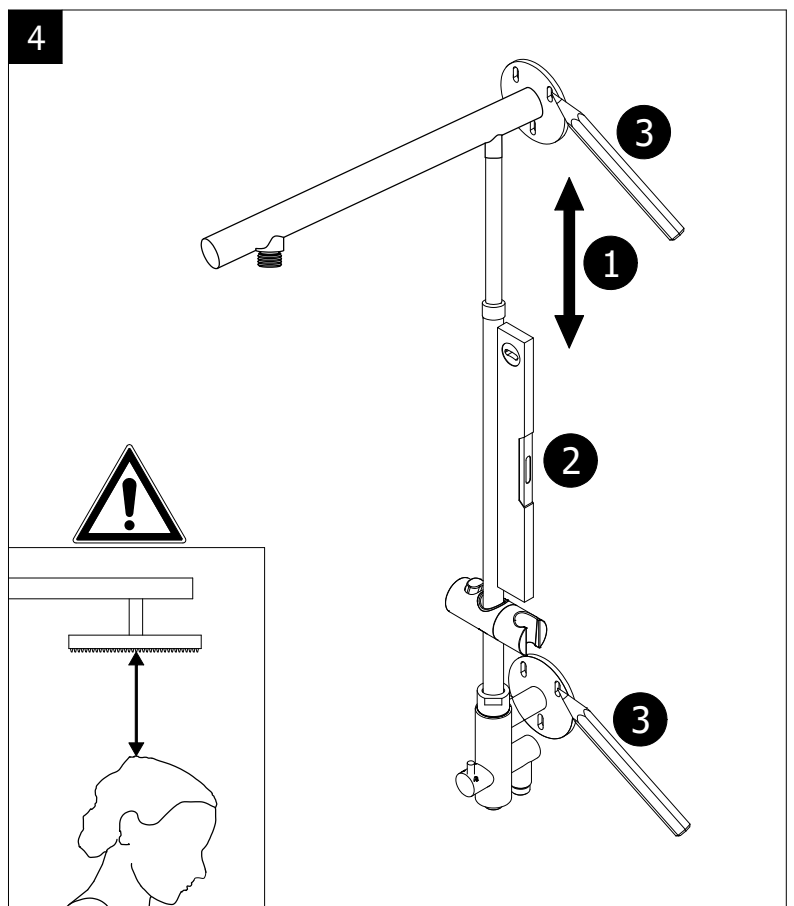
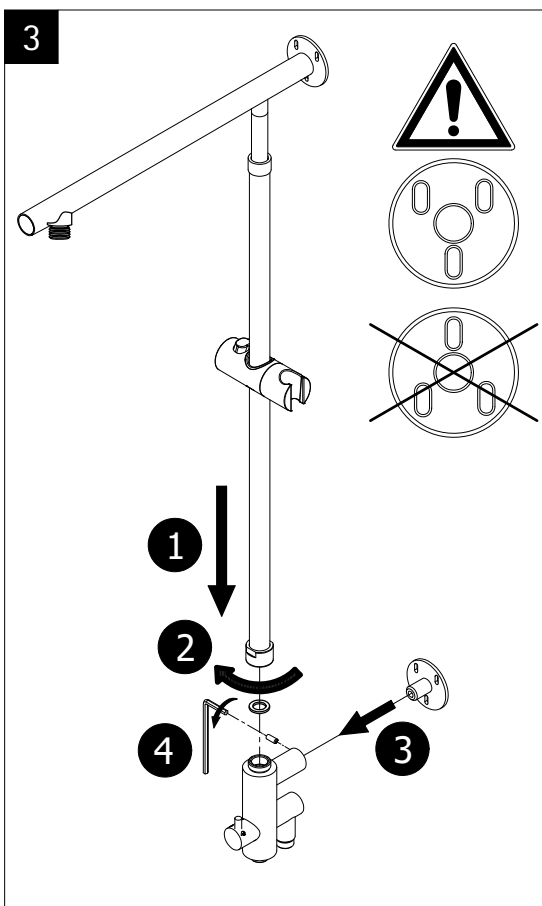
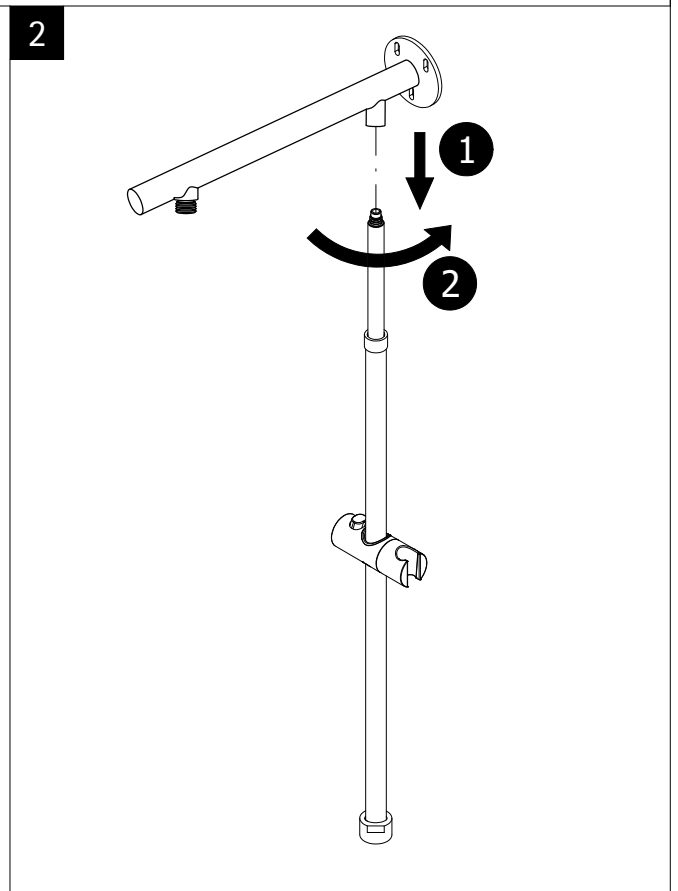
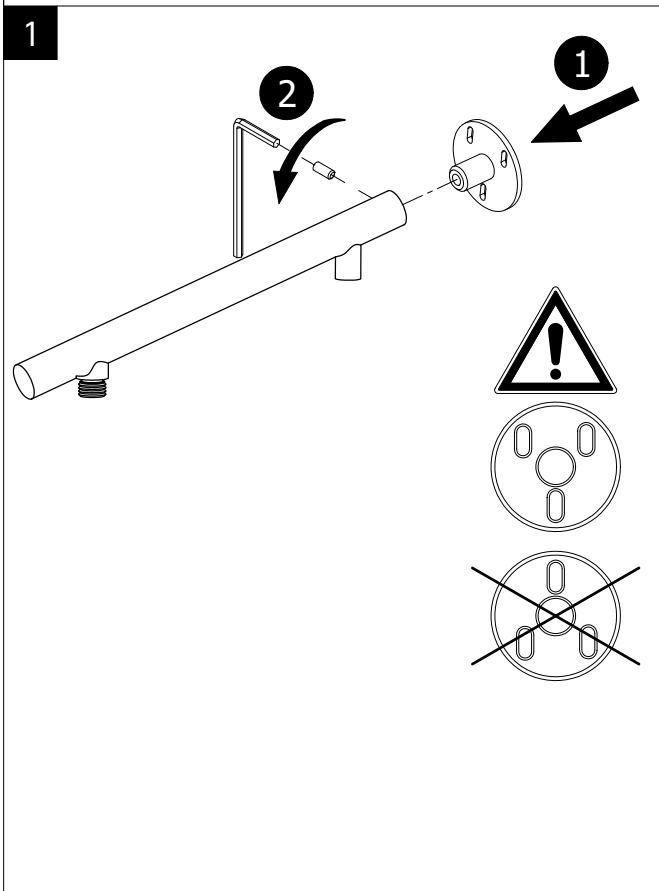
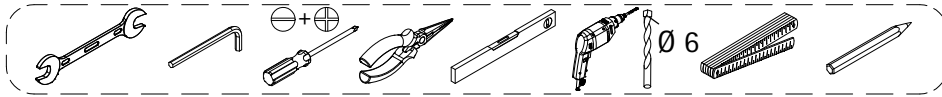

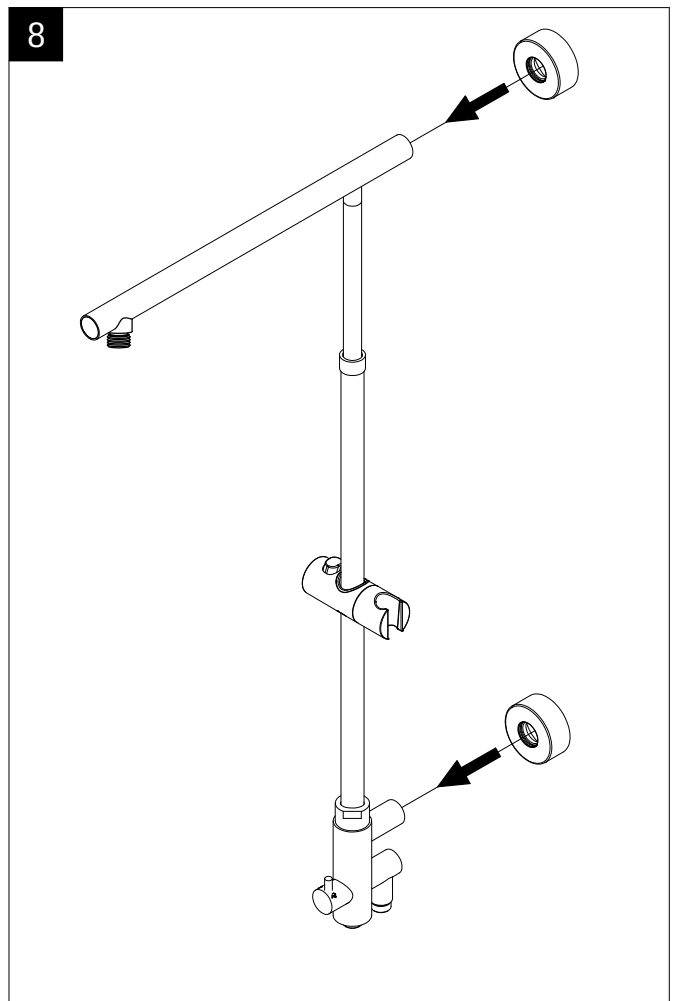
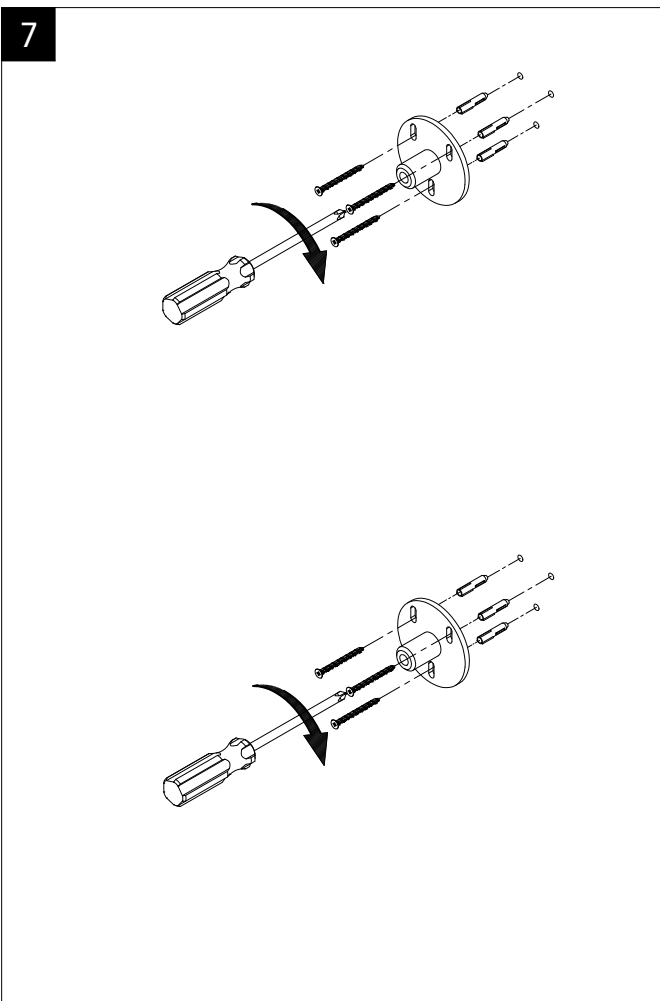
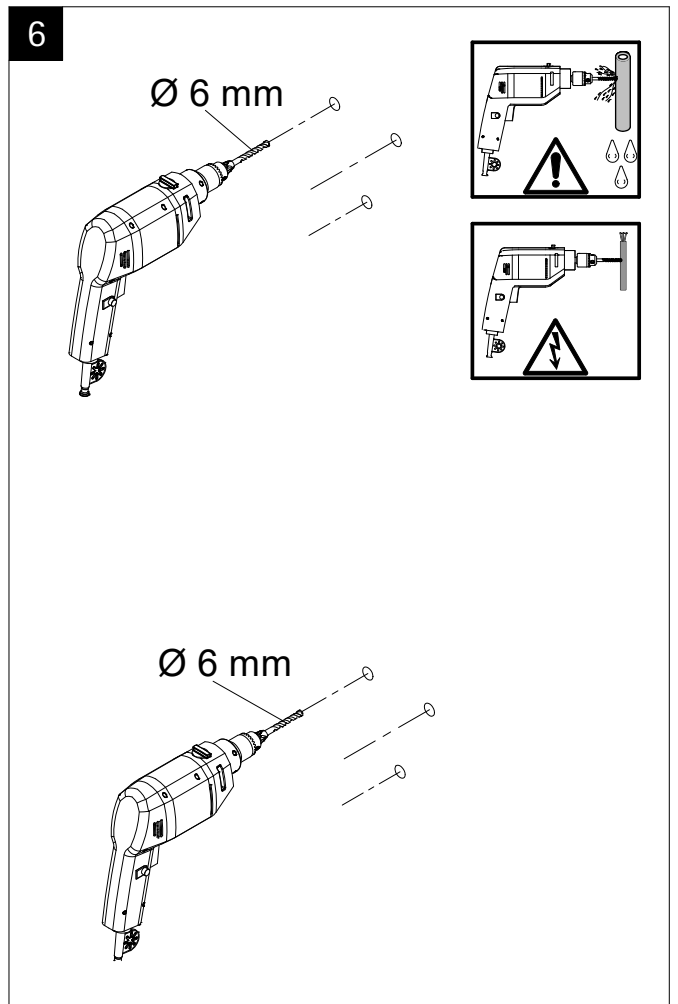
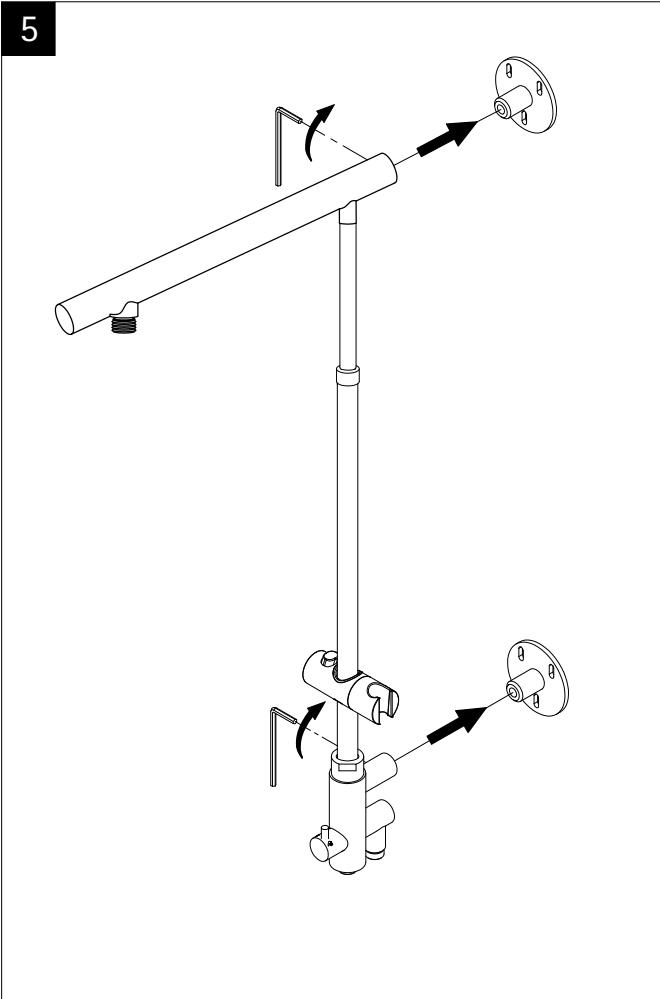

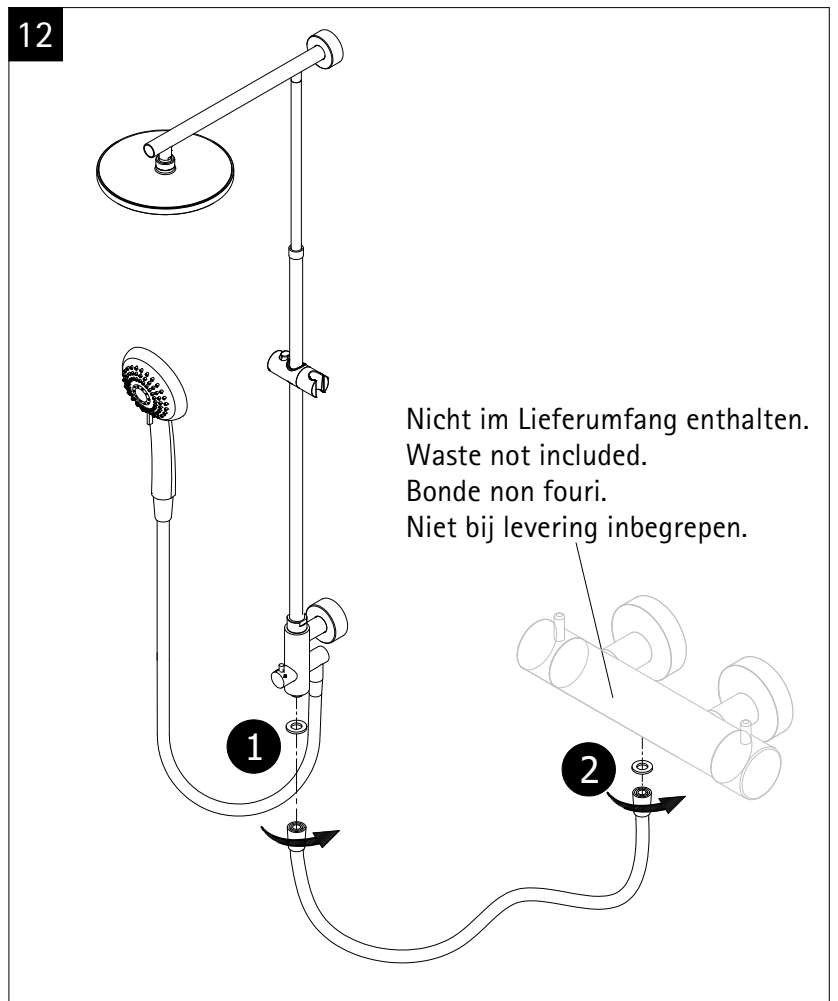
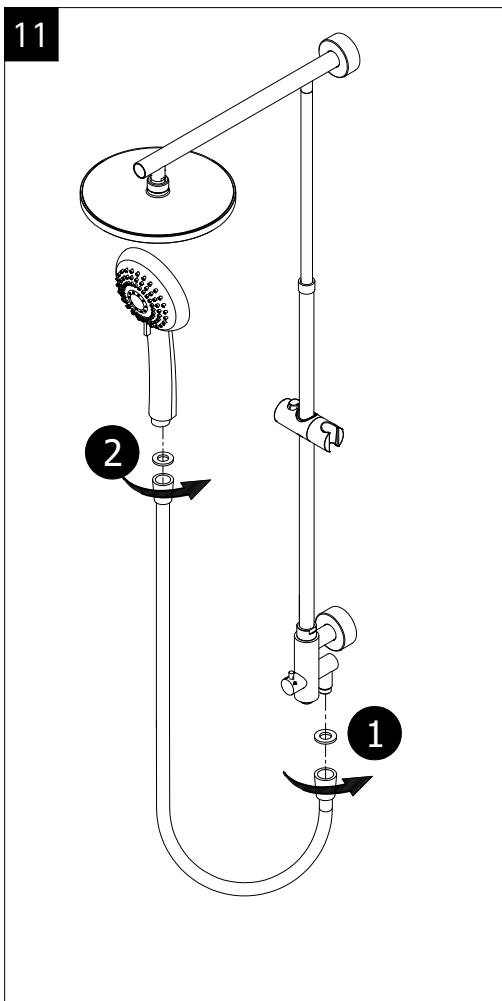
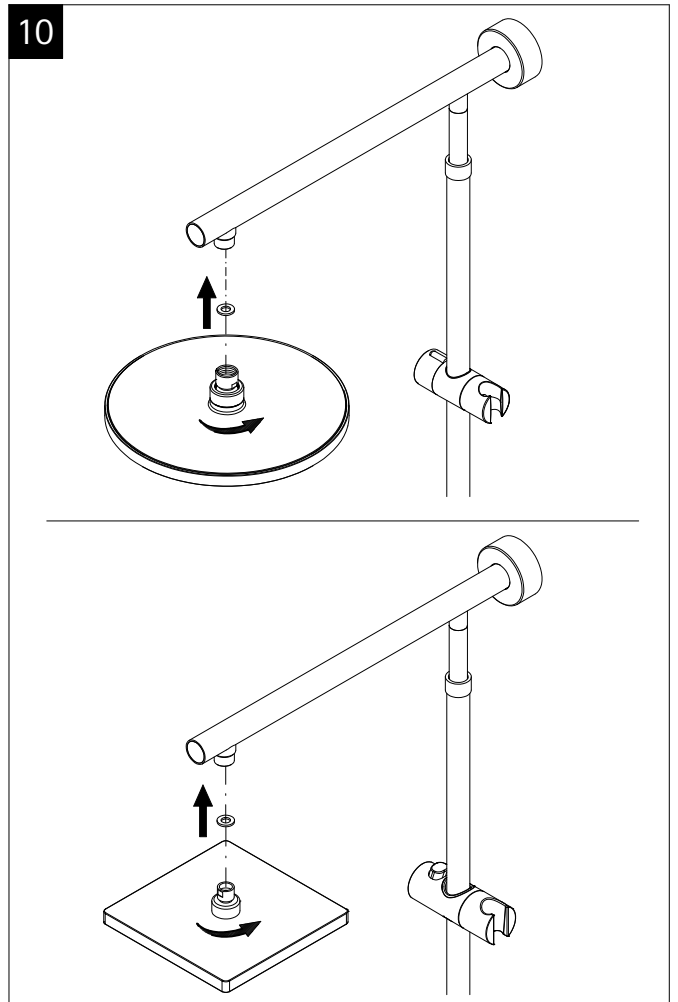
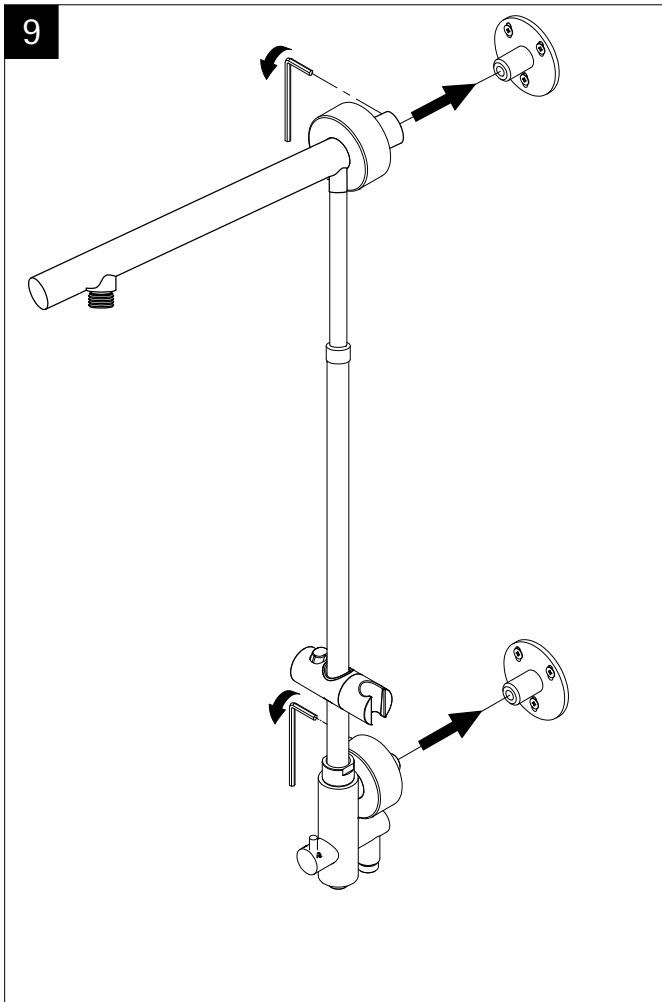

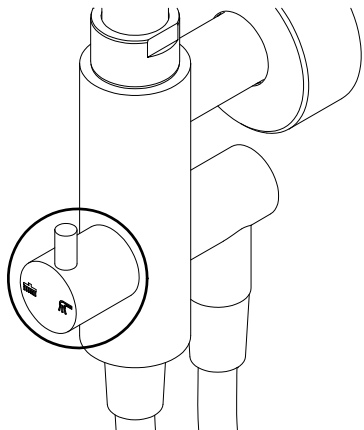

Info

de Umsteller wechseln.
Wasser abstellen!

en change the diverter.
turn of the water!

fr changez l'inverseur.
couper l'arrivée d'eau!

nl de omstelling wisselen.
water afsluiten!

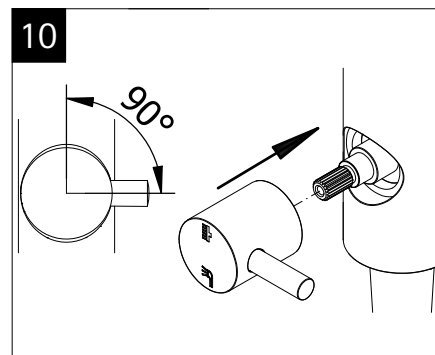
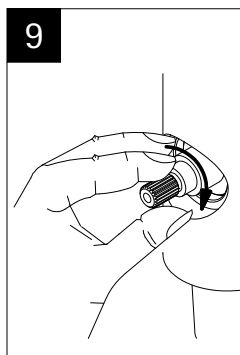
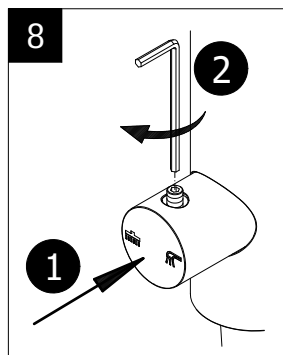
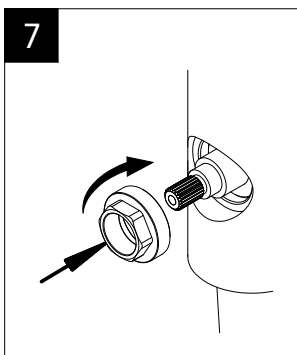
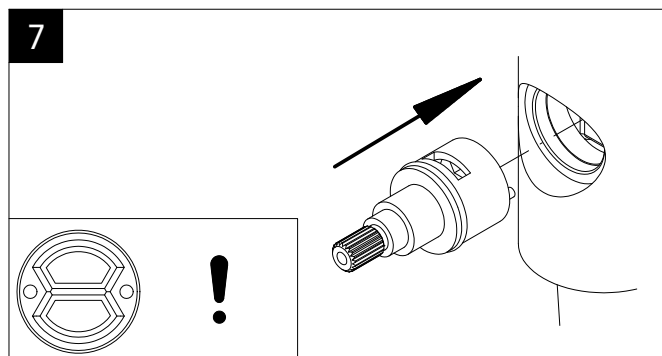
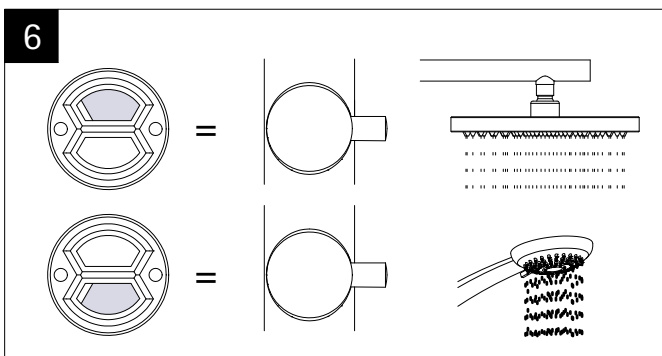
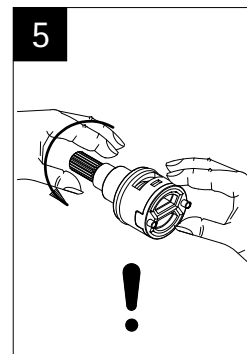
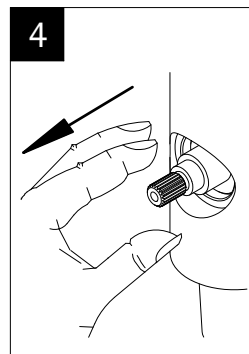
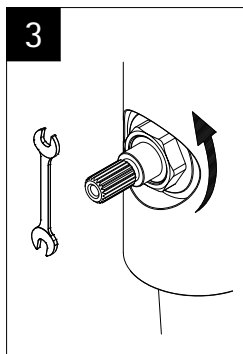
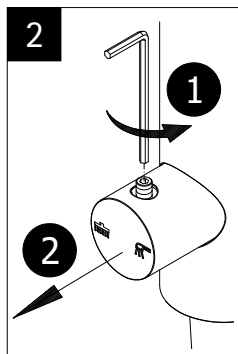
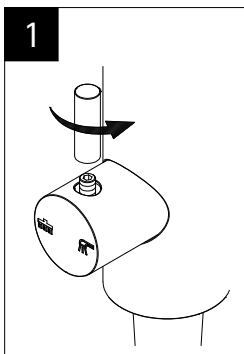

Info

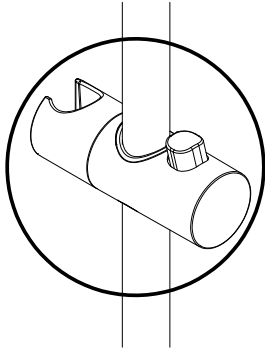

de Gleiter wecheln.
Wasser abstellen!

en Glider change.
turn of the water!

fr changement de planer.
couper l'arrivée d'eau!

nl Glijder wisselgeld.
water afsluiten!

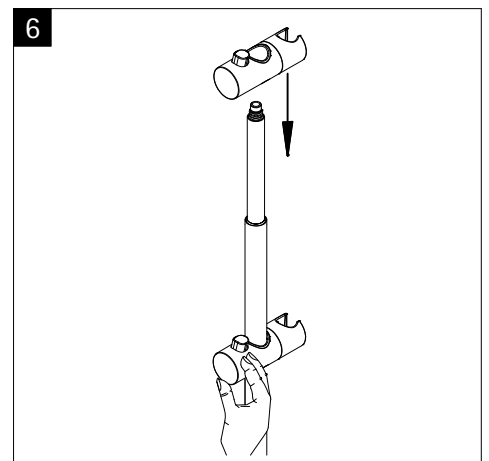
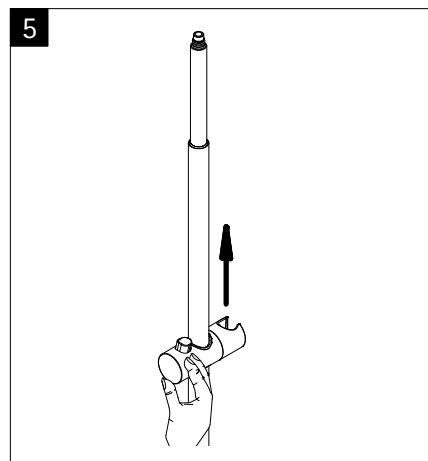
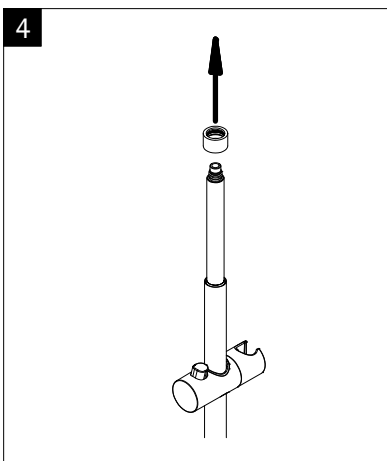
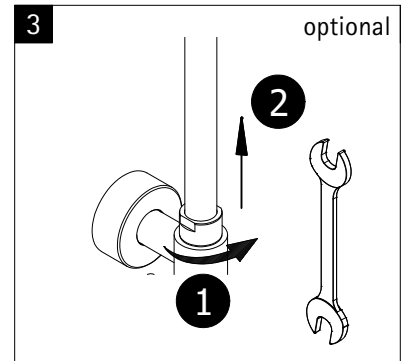
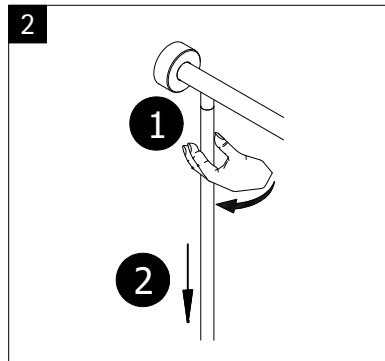
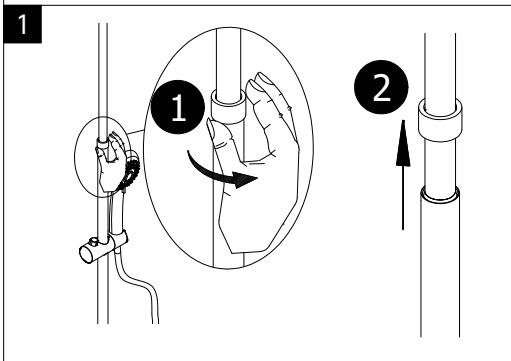

Info

de Einbau in umgekehrter Reihenfolge.

en Installation in the reverse order.

fr Montage dans le sense inverse.

nl Inbouw in omgekeerde volgorde.

Info

- de** Tropfende Brausen: Hand- und Kopfbrause
- en** dripping head or hand shower
- fr** pommeau haut ou dochette à main goutent
- nl** druipende dochekop of handdoche

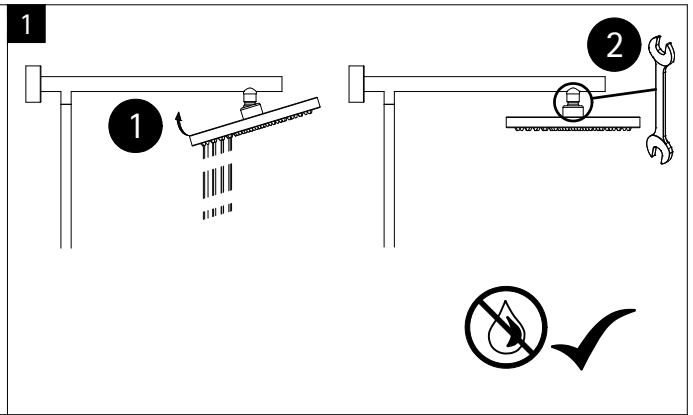

Info

- de** Tropfende Brausen: Hand- und Kopfbrause
- en** dripping head or hand shower
- fr** pommeau haut ou dochette à main goutent
- nl** druipende dochekop of handdoche

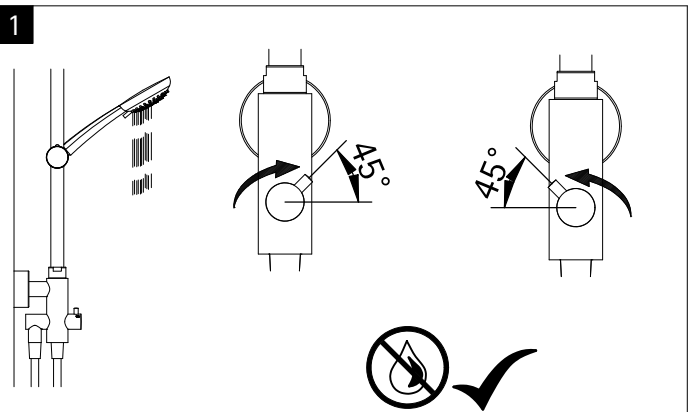

Info

- de** Handbrausehalter verdreht sich.
- en** Hand shower support twists
- fr** support de dochette à main torsade
- nl** handdochehouder draait

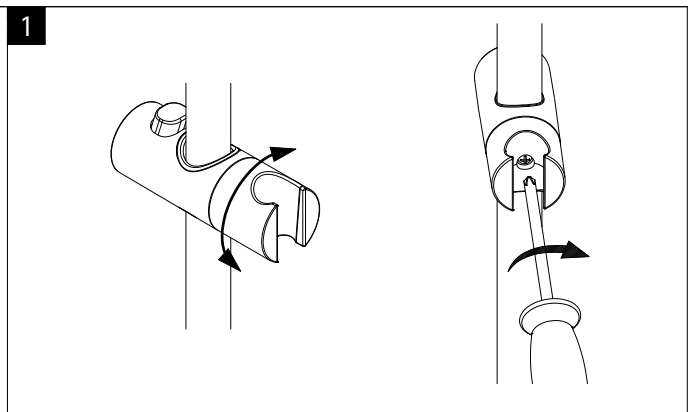

Notizen, notes, notities

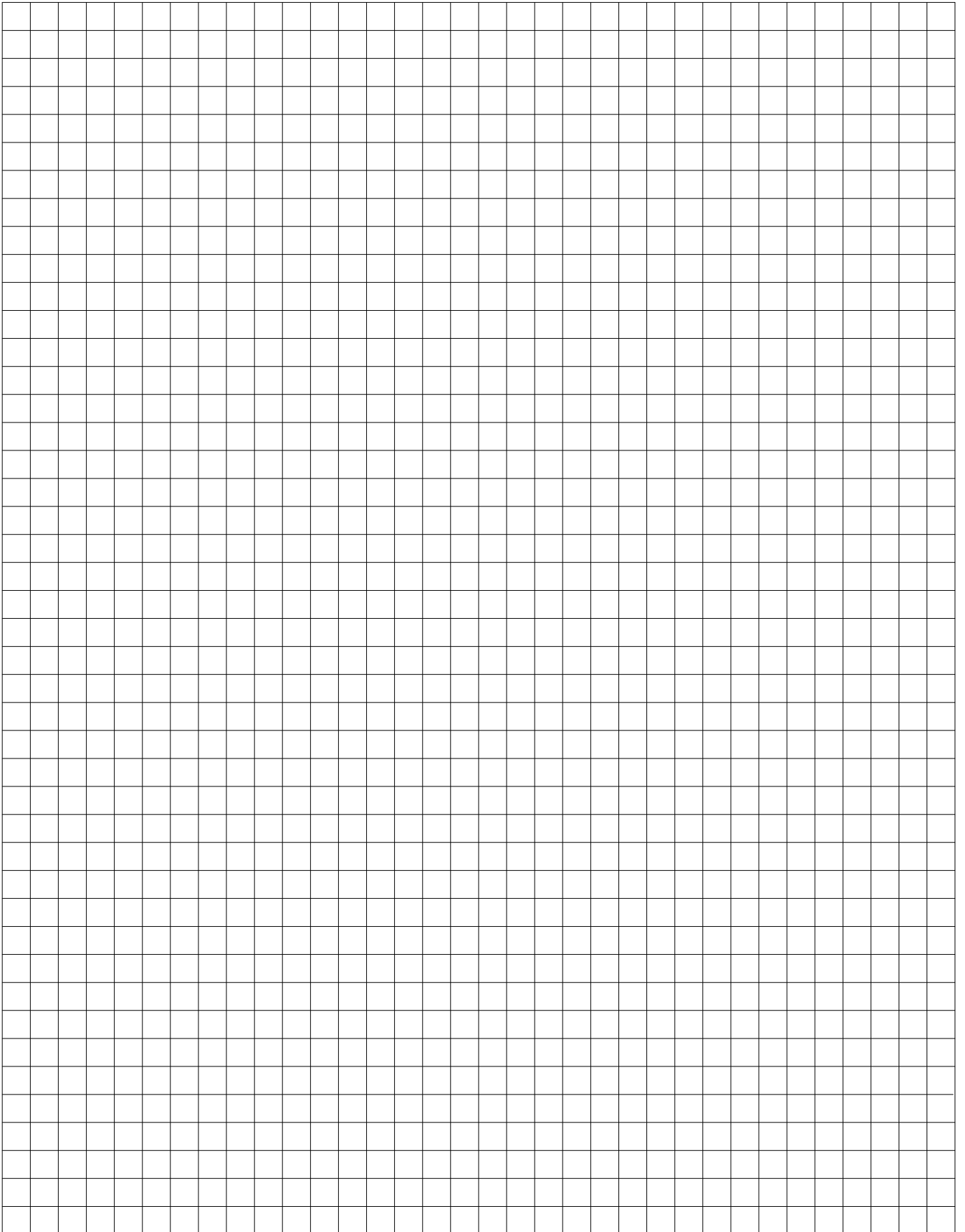

Notizen, notes, notities

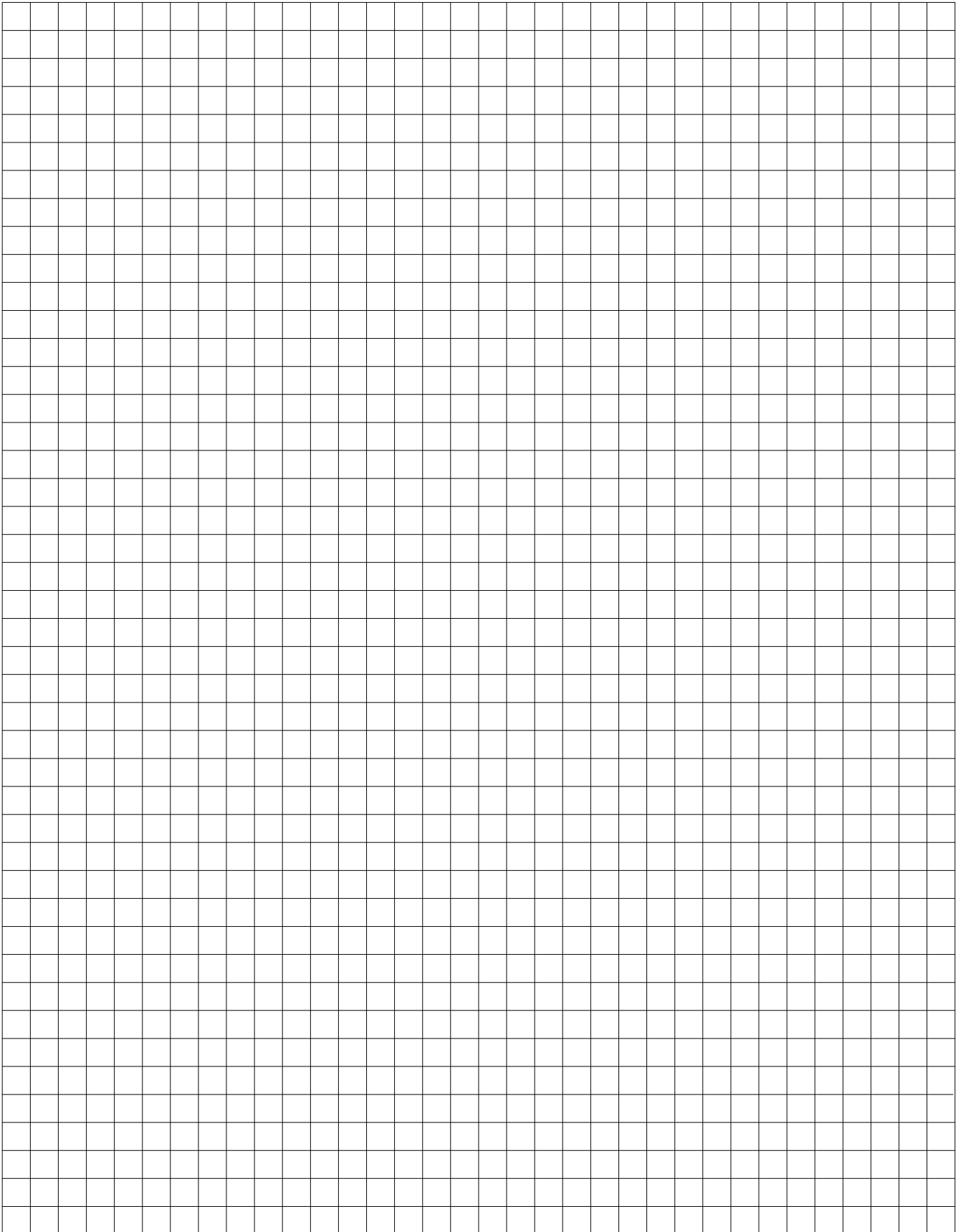

303-2

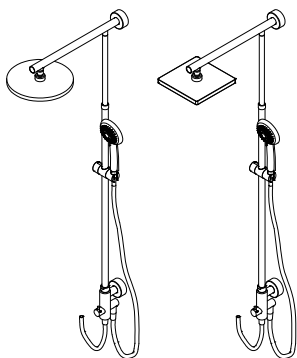

Kontrollbeleg
Control Receipt
Justificatif de contrôle
Controlé-attest

Prüfnummer/ Inspection number / Numéro d'essai / Controlnummer



Duschservice
Zum Hohlen Morgen 22
59939 Olsberg
Deutschland / Germany / Allemagne / Duitsland



Ersatzteilbestellung:
Fax 02962 / 972-4260



Allgemeine technische Probleme:
Telefon 02962 / 972-40



E-Mail:
ersatzteile@duschservice.de